

REVISION HISTORY			
REV	DESCRIPTION	DATE	APPROVED
1	Redraw	5/14/2008	narosenberg

Parts List			
ITEM	QTY	PART NUMBER	DESCRIPTION
1	2	FE-00001-01	Connector Tube
2	2	FE-00001-04	Connector Shaft
3	1	FE-00001-05	Support Column
4	1	FE-00001-03	Support Rail
5	1	FE-00001-02	Stop Plate

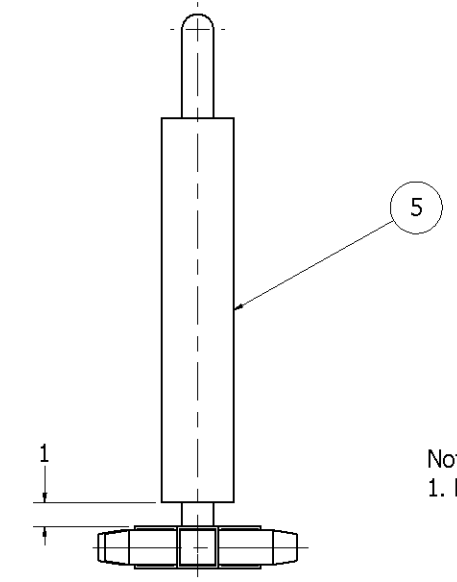
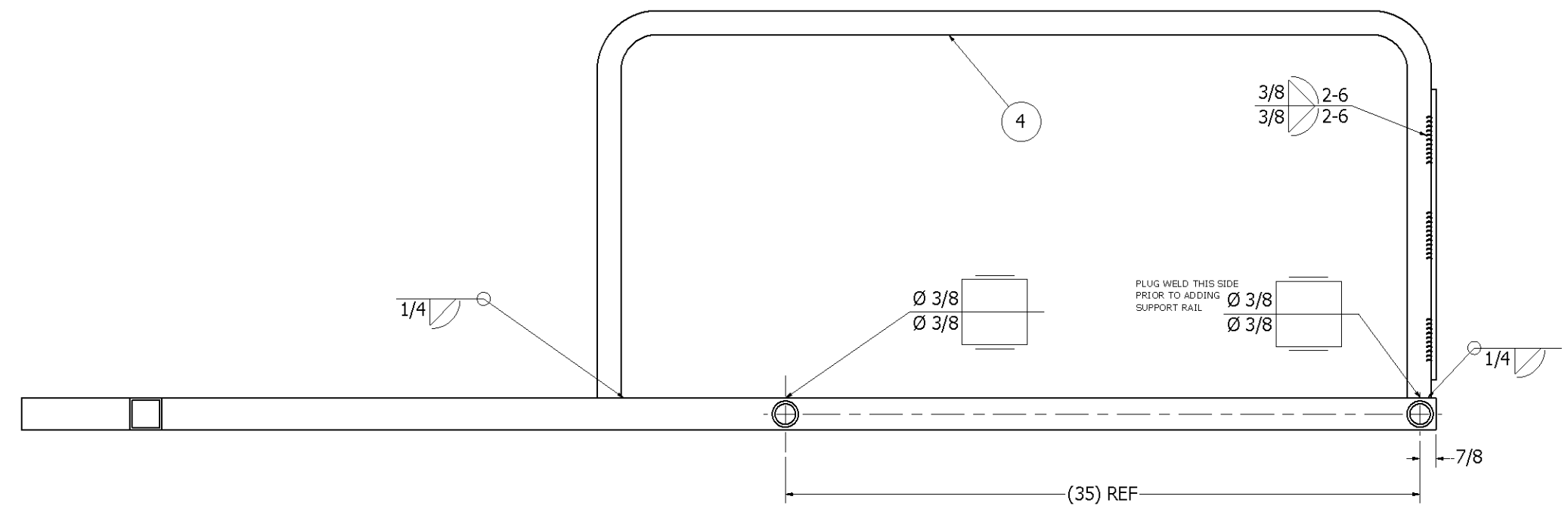
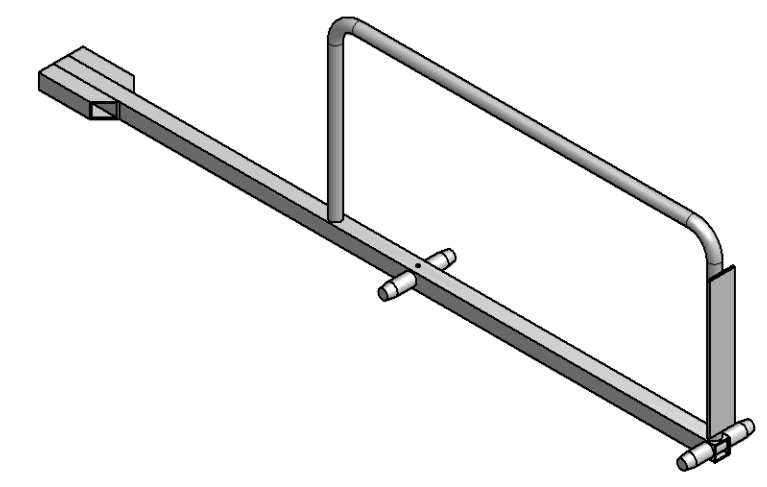
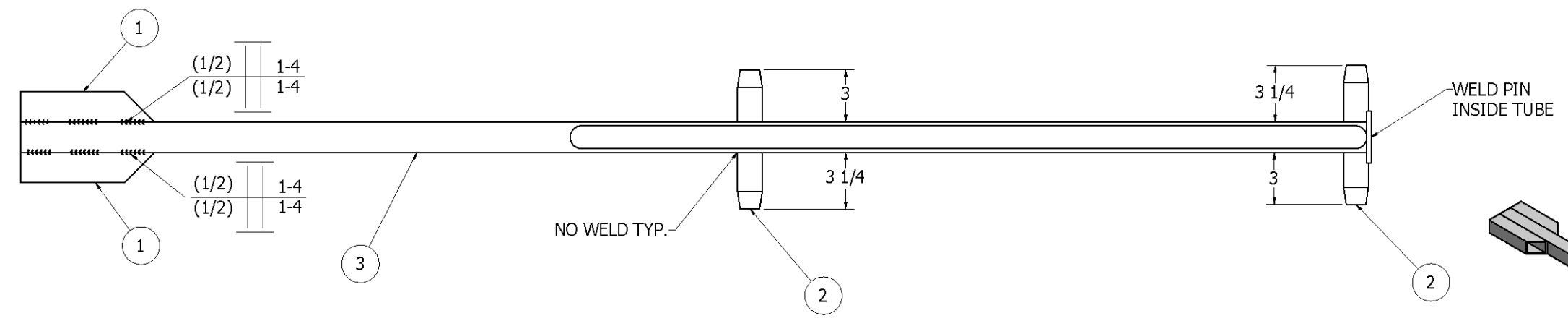

Notes:
1. Remove all sharp edges

DRAWN narosenberg	5/14/2008	FIRST 200 Bedford Street, Manchester, NH 03101 (603) 666-3906 -- FAX (603) 666-3907
CHECKED dfoster	8/1/2008	
UNLESS OTHERWISE SPECIFIED		TITLE DRIVERS STATION SUPPORT
FRAC.	+/- 1/32	SIZE DWG NO
.00	+/- .01	D FE-00001
.000	+/- .005	REV 1
ANGULAR	+/- .25 Deg.	SCALE
		SHEET 1 OF 2

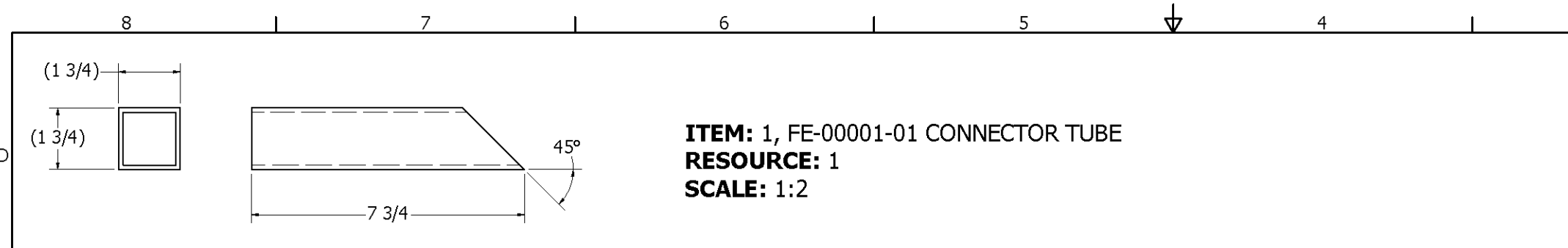

ITEM: 1, FE-00001-01 CONNECTOR TUBE
RESOURCE: 1
SCALE: 1:2

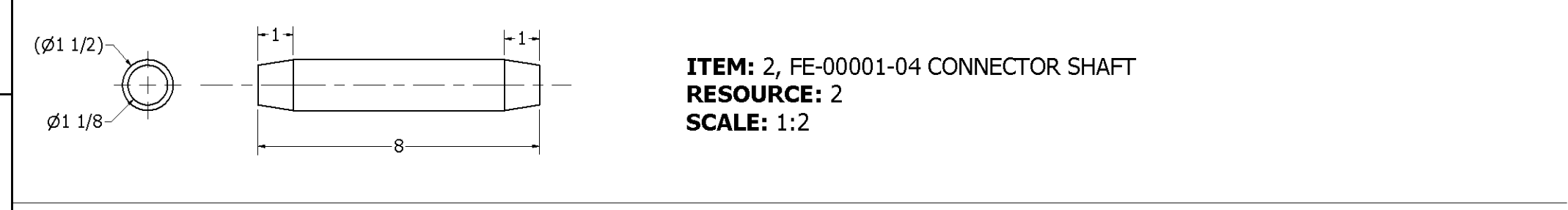

ITEM: 2, FE-00001-04 CONNECTOR SHAFT
RESOURCE: 2
SCALE: 1:2

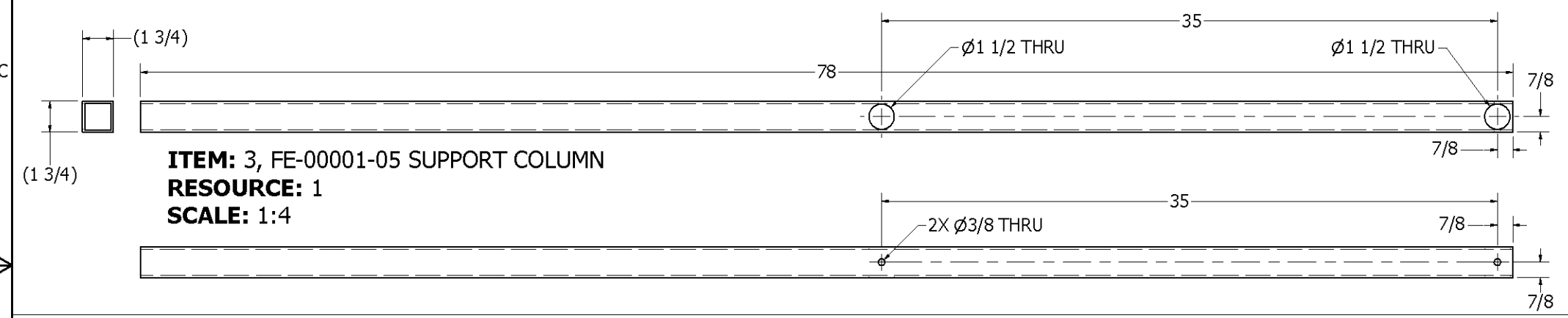

ITEM: 3, FE-00001-05 SUPPORT COLUMN
RESOURCE: 1
SCALE: 1:4

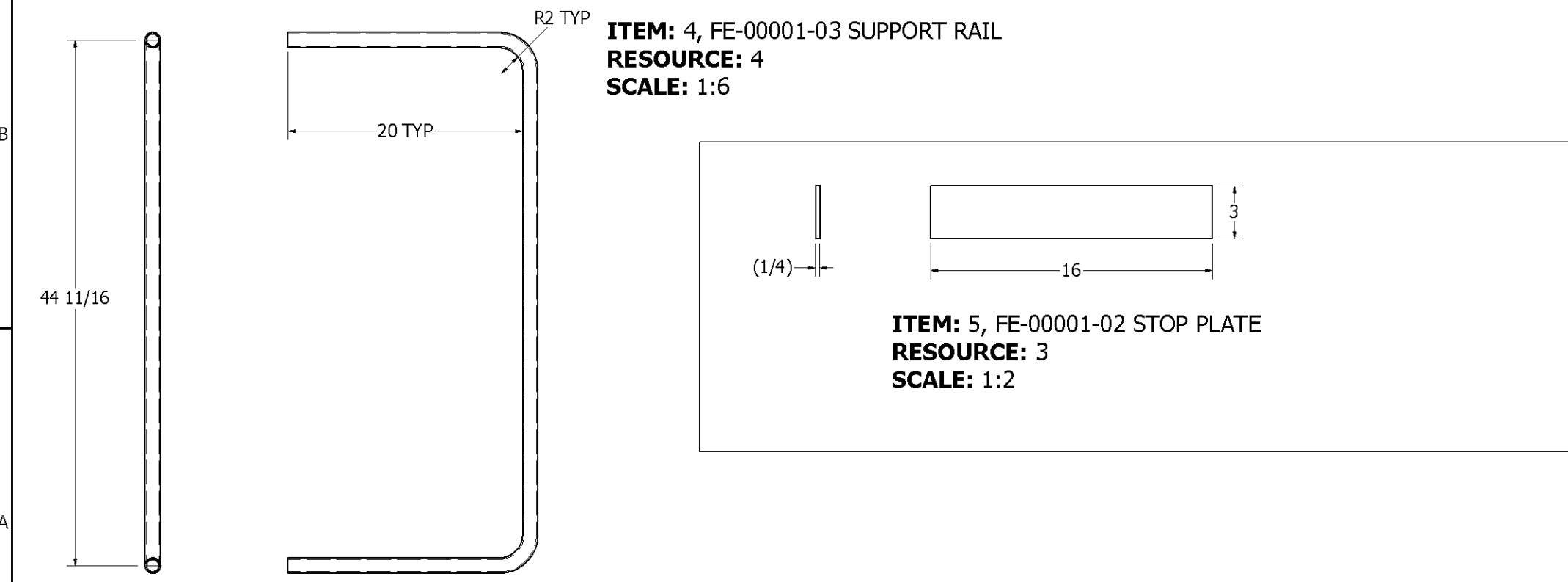

ITEM: 4, FE-00001-03 SUPPORT RAIL
RESOURCE: 4
SCALE: 1:6

ITEM: 5, FE-00001-02 STOP PLATE
RESOURCE: 3
SCALE: 1:2

RESOURCE	QTY.	RESOURCES		
		DESCRIPTION	LENGTH	PART NO.
1	AR	1 3/4" X 1 3/4" X 1/8' 6061 ALUMINUM TUBING		-
2	AR	1 1/2" 6061 ALUMINUM SOLID ROD		-
3	AR	1/4" 6061 ALUMINUM PLATE		-
4	AR	1" SCHEDULE 40 ALUMINUM TUBE		-

DRAWN narosenberg	5/14/2008	FIRST 200 Bedford Street, Manchester, NH 03101 (603) 666-3906 -- FAX (603) 666-3907
CHECKED dfoster	8/1/2008	
UNLESS OTHERWISE SPECIFIED		TITLE DRIVERS STATION SUPPORT
FRAC.	+/- 1/32	
.00	+/- .01	SIZE DWG NO
.000	+/- .005	D FE-00001
ANGULAR	+/- .25 Deg.	SCALE
		REV 1
		SHEET 2 OF 2

REVISION HISTORY			
REV	DESCRIPTION	DATE	APPROVED
1	Redraw	5/19/2008	narosenberg

FE-00002 Corner Support Assy			
ITEM	QTY	PART NUMBER	DESCRIPTION
1	1	FE-00002-01	Connector Shaft A
2	1	FE-00002-02	Connector Shaft B
3	1	FE-00002-03	Connector Tube
5	1	FE-00002-05	Support Column for Corner
6	1	FE-00002-06	Support Rail
7	1	FE-00002-07	Stop Plate
9	2	FE-00002-09	Mounting coupler

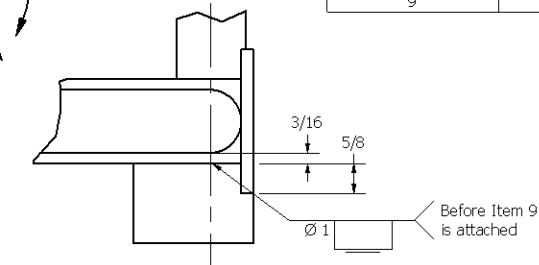
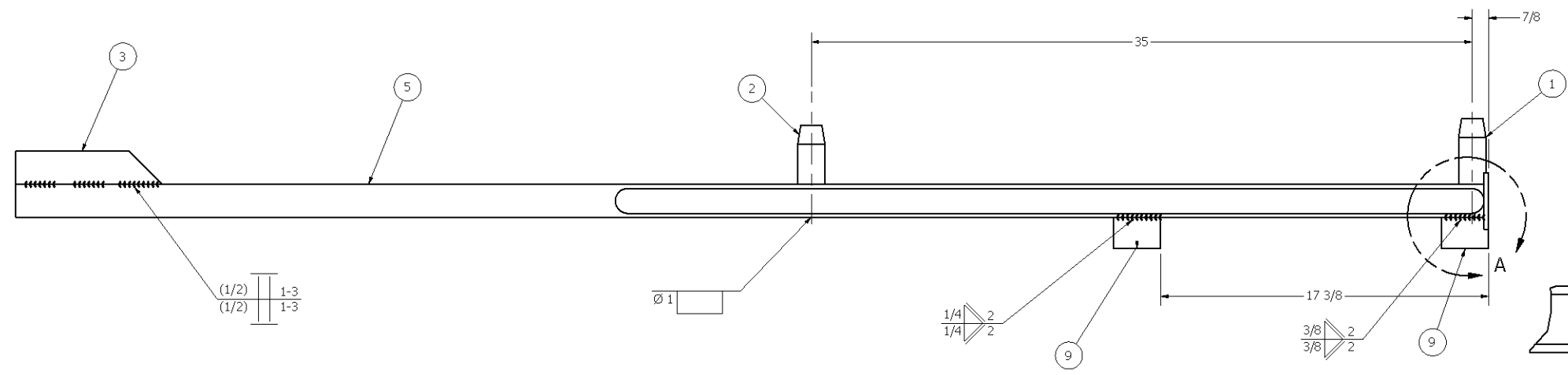

DETAIL A
SCALE 1/2

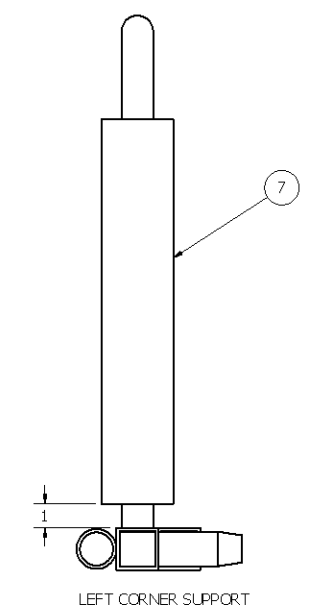
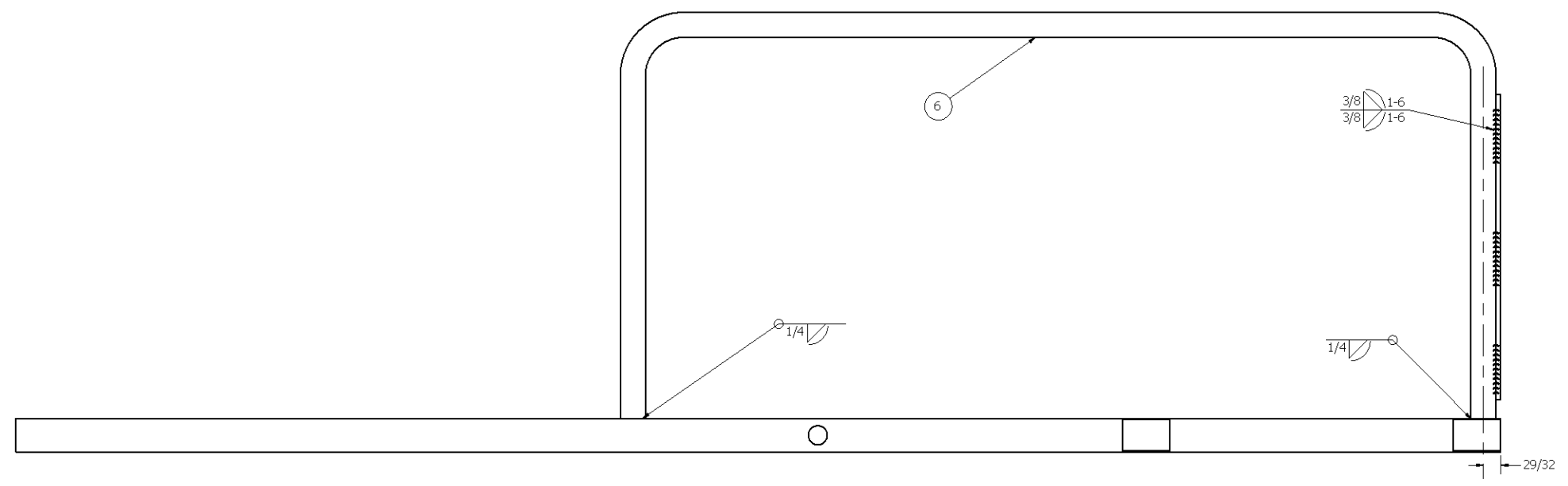

LEFT CORNER SUPPORT

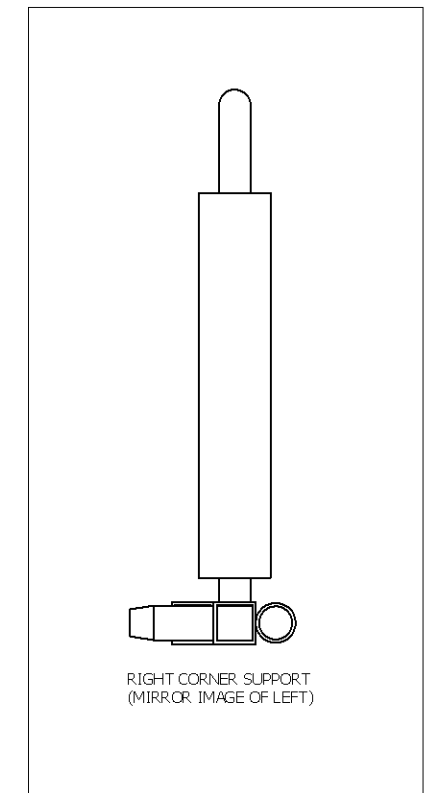

RIGHT CORNER SUPPORT
(MIRROR IMAGE OF LEFT)

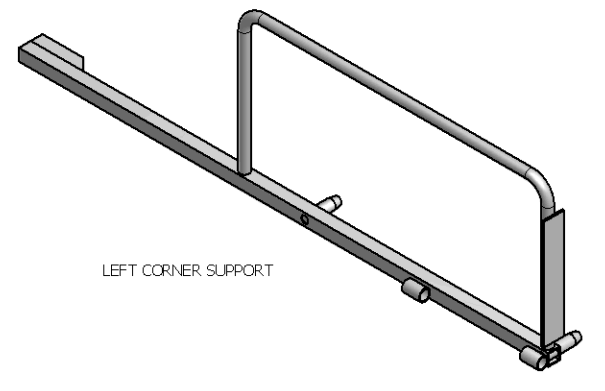

LEFT CORNER SUPPORT

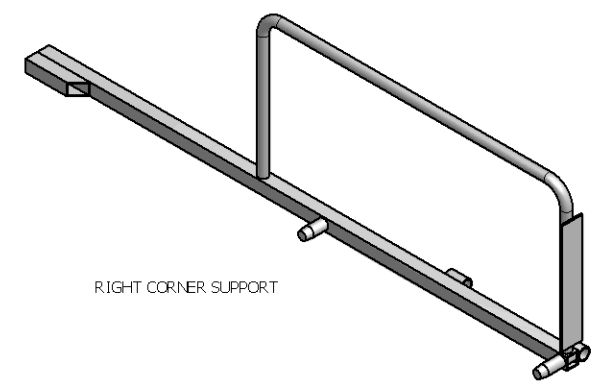

RIGHT CORNER SUPPORT

- Notes:
1. Left corner support shown, right is same components, mirror image assy
 2. Remove all sharp edges

DRAWN narosenberg	5/19/2008	FIRST 200 Bedford Street, Manchester, NH 03101 (603) 666-3906 -- FAX (603) 666-3907
CHECKED dfoster	8/12/2008	
UNLESS OTHERWISE SPECIFIED		TITLE Corner Supports, Left and Right
FRAC.	+/- 1/32	SIZE DWG NO
.00	+/- .01	D FE-00002
.000	+/- .005	SCALE
ANGULAR	+/- .25 Deg.	SHEET 1 OF 2

RESOURCES				
RESOURCE	QTY.	DESCRIPTION	LENGTH	PART NO.
1		1 7/16" Dia. 6061 Aluminum Solid Rod		
2		1 3/4" x 1 3/4" x 1/8" 6061 Aluminum Tubing		
4		1" Schedule 40 Aluminum Tube		
5		3" x 1/4" 6061 Aluminum Bar		
6		1 1/4" Schedule 40 Aluminum Tube		

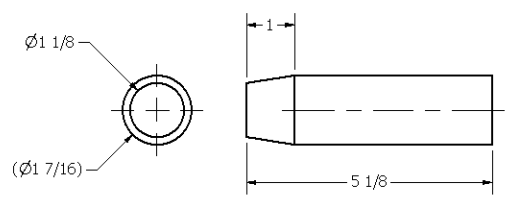

ITEM: 1, FE-00002-01 Connector Shaft A
RESOURCE: 1
SCALE: 1/2

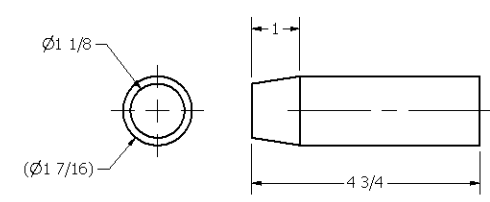

ITEM: 1, FE-00002-02 Connector Shaft B
RESOURCE: 1
SCALE: 1/2

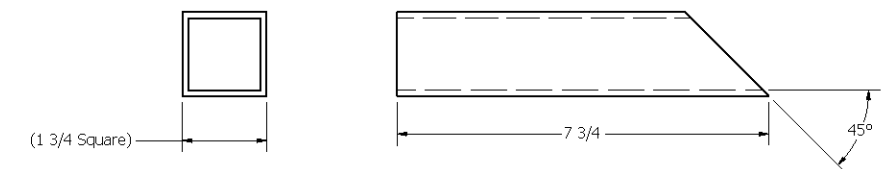

ITEM: 3, FE-00002-03 Connector Tube
RESOURCE: 2
SCALE: 1/2

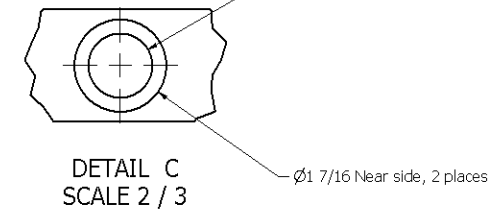
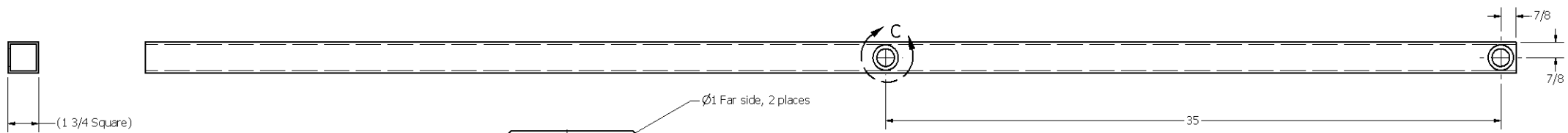
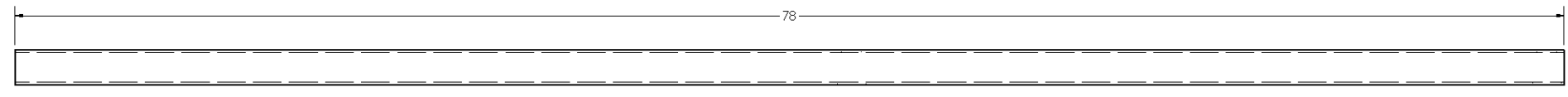

ITEM: 5, FE-00002-05 Support Column for Corner
RESOURCE: 2
SCALE: 1/4

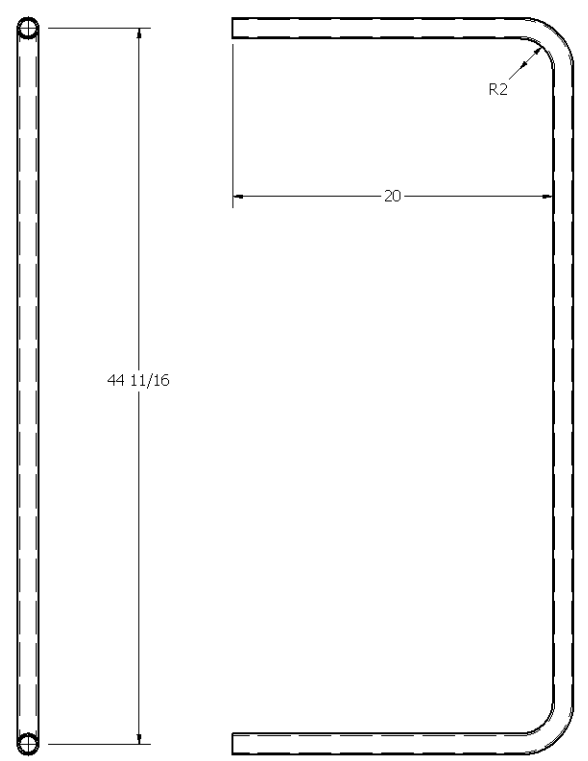

ITEM: 6, FE-00002-06 Support Rail
RESOURCE: 4
SCALE: 1/6

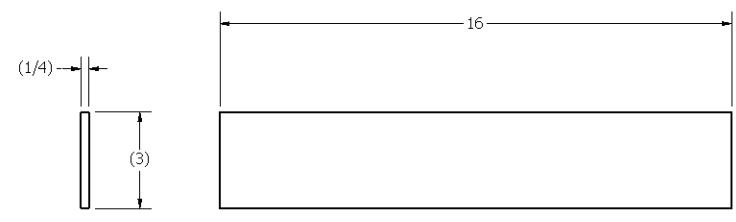

ITEM: 7, FE-00002-07 Stop Plate
RESOURCE: 5
SCALE: 1/3

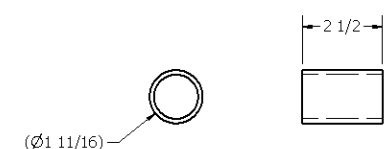

ITEM: 9, FE-00002-09 Mounting Coupler
RESOURCE: 6
SCALE: 1/3

DRAWN narosenberg	5/19/2008	FIRST 200 Bedford Street, Manchester, NH 03101 (603) 666-3906 -- FAX (603) 666-3907
CHECKED dfoster	8/12/2008	
UNLESS OTHERWISE SPECIFIED		TITLE Corner Supports, Left and Right
FRAC.	+/- 1/32	SIZE DWG NO D FE-00002
.00	+/- .01	REV 1
.000	+/- .005	SCALE
ANGULAR	+/- .25 Deg.	SHEET 2 OF 2

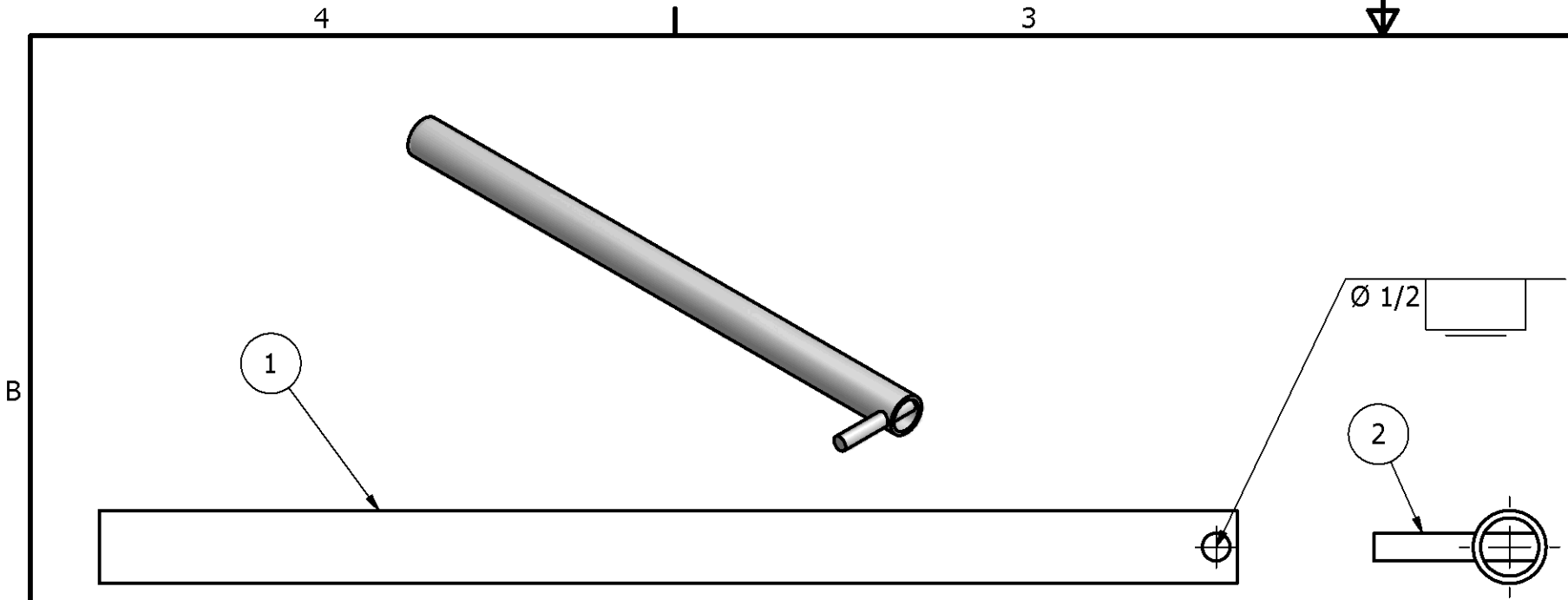
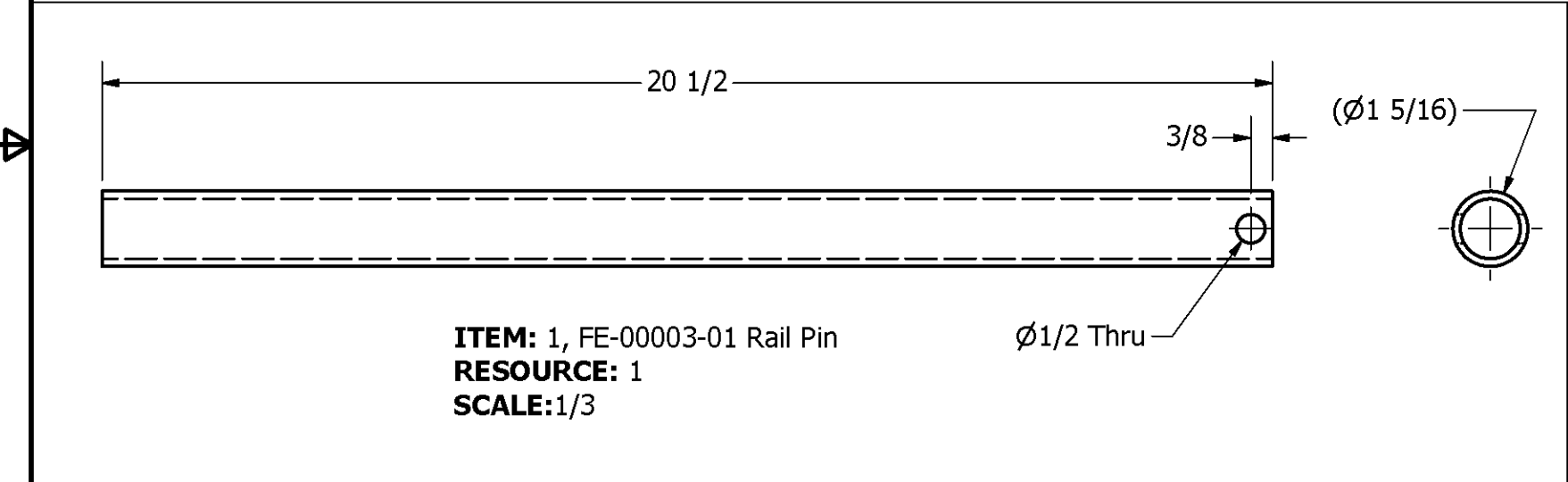

Table			
REV	DESCRIPTION	DATE	APPROVED
1	Redraw	5/20/2008	narosenberg

FE-00003 Rail Pin Assy Parts List			
ITEM	QTY	PART NUMBER	DESCRIPTION
1	1	FE-00003-01	Rail Pin
2	1	FE-00003-02	Pull Rod

RESOURCES				
RESOURCE	QTY.	DESCRIPTION	LENGTH	PART NO.
1		1" Schedule 40 6061 Aluminum Tube		
2		1/2" 6061 Aluminum Rod		



ITEM: 1, FE-00003-01 Rail Pin
RESOURCE: 1
SCALE: 1/3

Notes:
 1. Remove all sharp edges

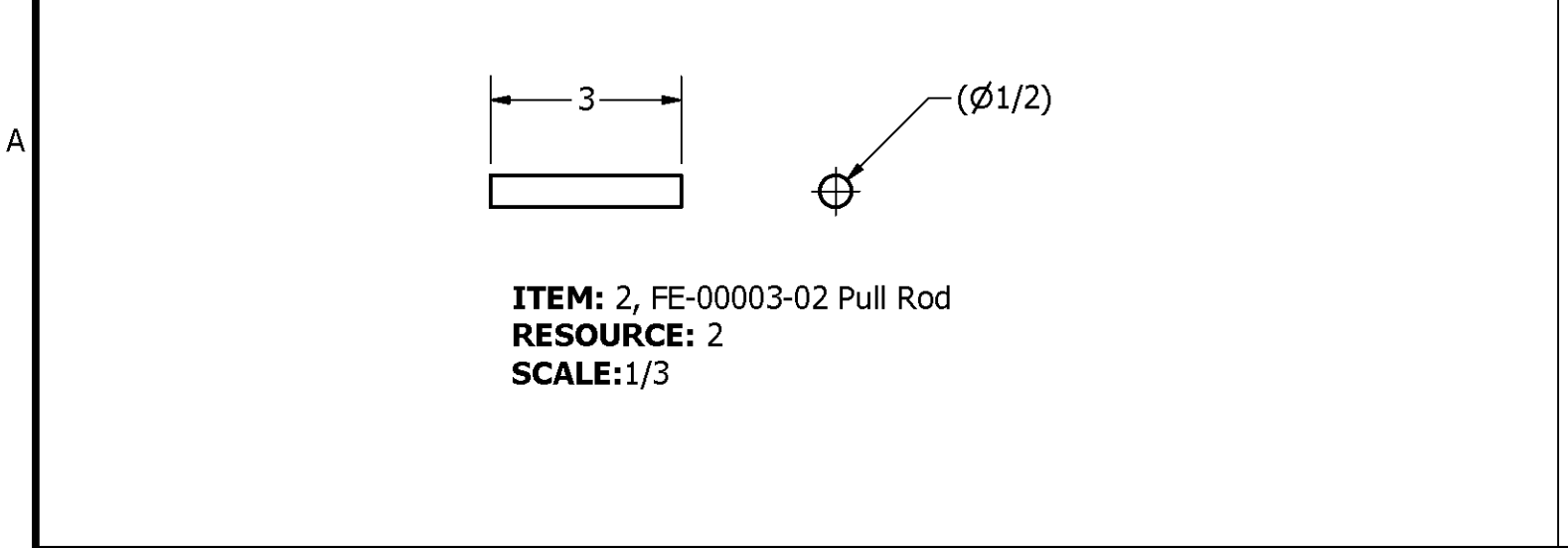

ITEM: 2, FE-00003-02 Pull Rod
RESOURCE: 2
SCALE: 1/3

DRAWN narosenberg	5/20/2008
CHECKED dfoster	7/31/2008
UNLESS OTHERWISE SPECIFIED	
TOLERANCES: (INCHES)	
FRAC.	+/- 1/32
.00	+/- .01
.000	+/- .005
ANGULAR	+/- .25 Deg.

FIRST
 200 Bedford Street, Manchester, NH 03101
 (603) 666-3906 -- FAX (603) 666-3907

TITLE
Rail Pin Assy

SIZE B	DWG NO FE-00003	REV
SCALE	SHEET 1 OF 1	

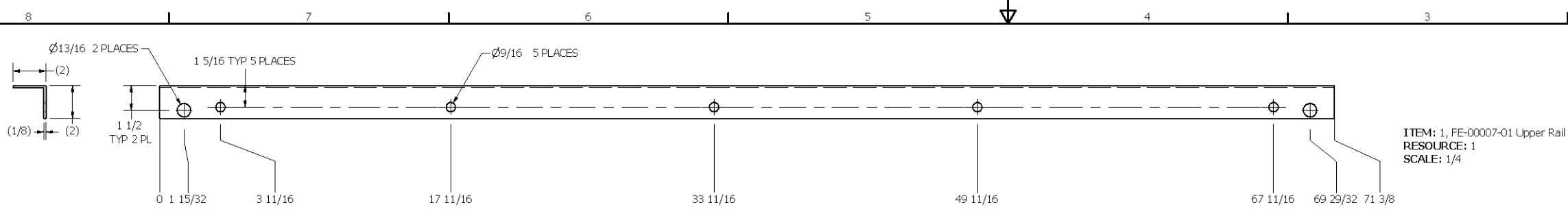

ITEM: 1, FE-00007-01 Upper Rail
 RESOURCE: 1
 SCALE: 1/4

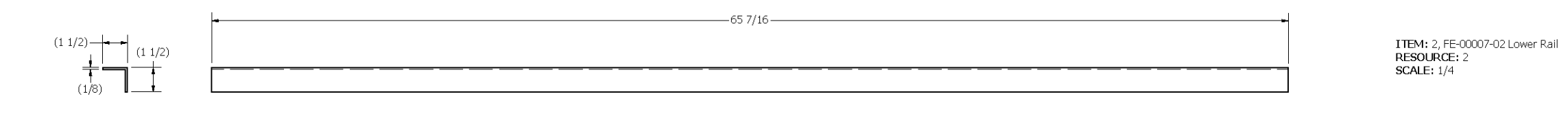

ITEM: 2, FE-00007-02 Lower Rail
 RESOURCE: 2
 SCALE: 1/4

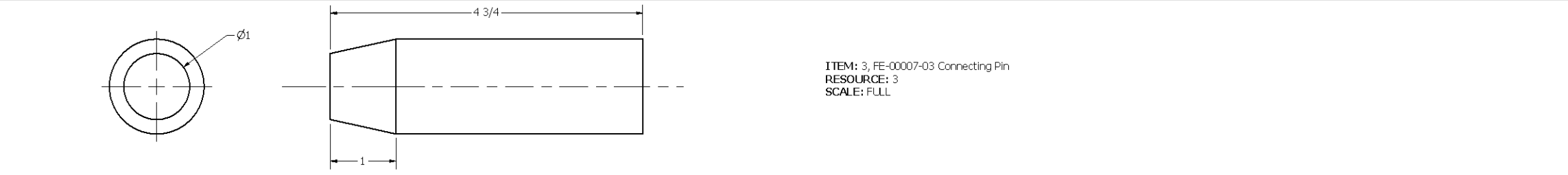

ITEM: 3, FE-00007-03 Connecting Pin
 RESOURCE: 3
 SCALE: FULL

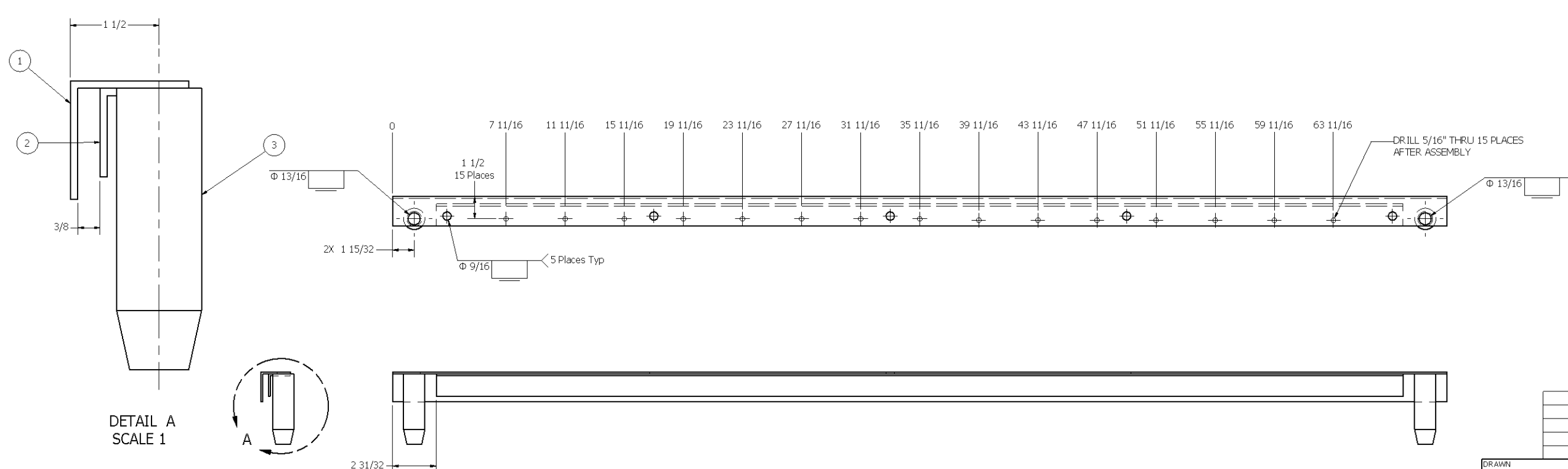

DETAIL A
 SCALE 1

DRILL 5/16" THRU 15 PLACES
 AFTER ASSEMBLY

REVISION HISTORY				
ZONE	REV	DESCRIPTION	DATE	APPROVED
	1	Redrawn	5/27/2008	narosenberg

RESOURCES				
RESOURCE	QTY	DESCRIPTION	LENGTH	PART NO.
1		2" x 2" X 1/8" SQ CORNER 6063 ALUM ANGLE		
2		1 7/16" ALUM ROUND STOCK		
3		1 1/2 X 1 1/2 X 1/8" 6061 ALUM ANGLE		

FE-00007 Field Top Rail Parts List			
ITEM	QTY	PART NUMBER	DESCRIPTION
1	1	FE-00007-01	Upper Rail
2	1	FE-00007-02	Lower Rail
3	2	FE-00004-03	Connecting Pin

DRAWN narosenberg	5/27/2008	FIRST 200 Bedford Street, Manchester, NH 03101 (603) 666-3906 -- FAX (603) 666-3907
CHECKED dfoster	3/4/2008	
UNLESS OTHERWISE SPECIFIED		TITLE FIELD TOP RAIL
FRAC.	+/- 1/32	SIZE DWG NO
.00	+/- .01	D FE-00007
.000	+/- .005	REV 1
ANGULAR	+/- .25 Deg.	SCALE
		SHEET 1 OF 1

Notes:
 1. Remove all sharp edges and burrs

8 7 6 5 4 3 2 1

Revisions			
REV	DESCRIPTION	DATE	APPROVED
1	Redraw	5/20/2008	narosenberg

Parts List			
ITEM	QTY	PART NUMBER	DESCRIPTION
1	1	FE-00004-01	Panel, Diamond Plate
2	2	FE-00004-02	Hinge, End Shelf
3	1	FE-00004-03	Hinge, Middle Shelf
4	2	FE-00004-04	Support, Top and Bottom
5	1	FE-00004-05	Support, Window
6	1	FE-00004-06	Shelf
7	2	FE-00004-07	Hinge, Stop Plate
8	2	FE-00004-08	Hinge, Shelf Support
9	2	FE-00004-09	Plate, Shelf Support
10	2	FE-00004-10	Plate, Stop

Notes:
1. Remove all sharp edges and burrs

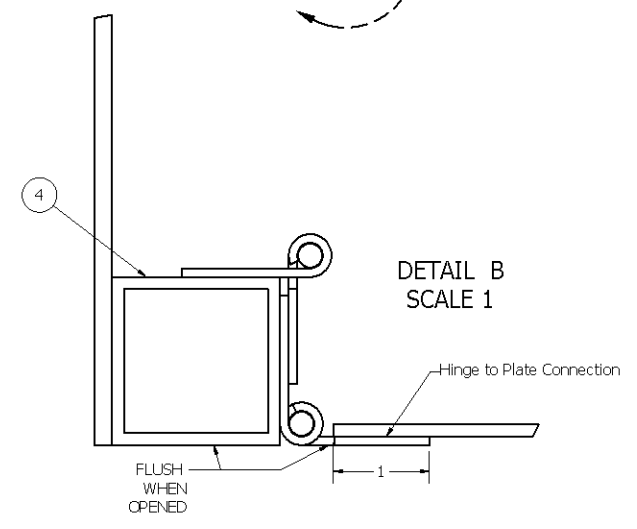
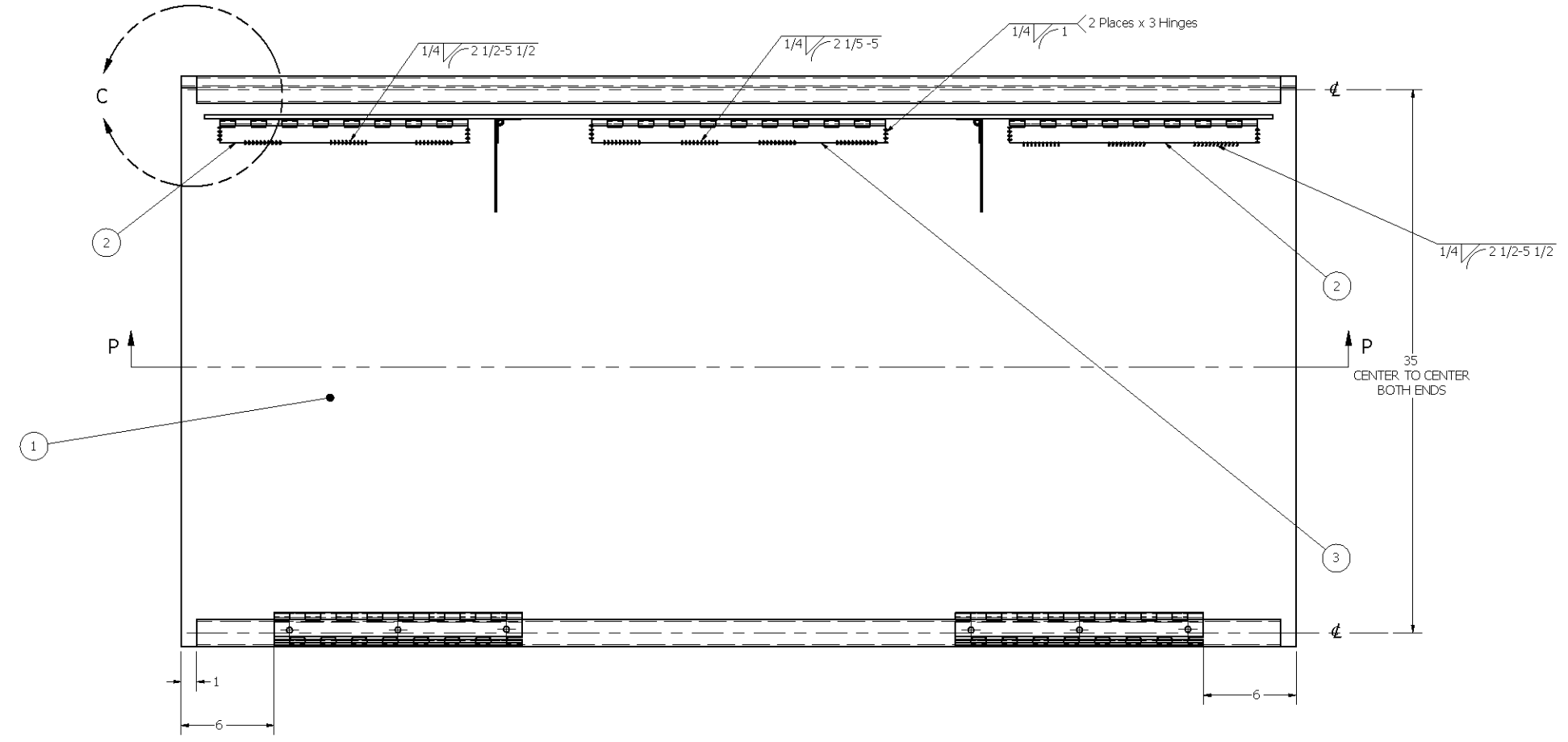
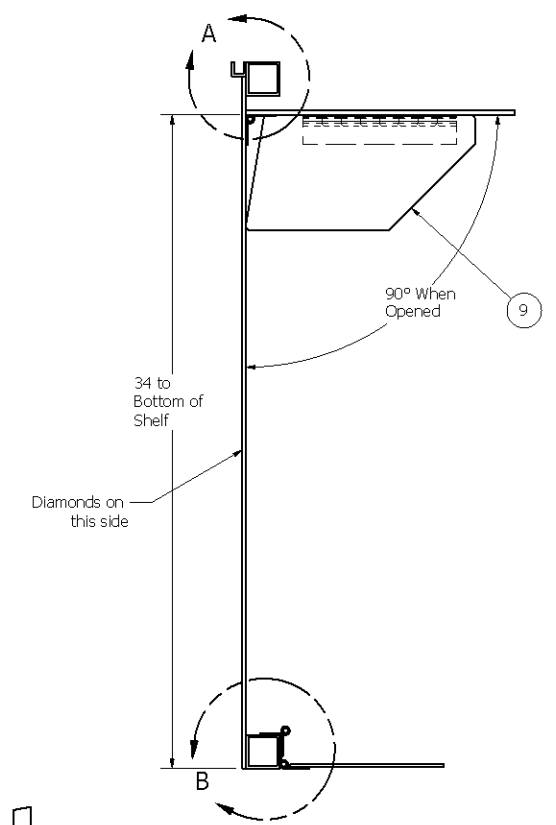
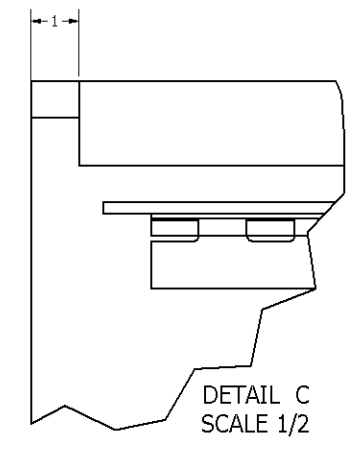
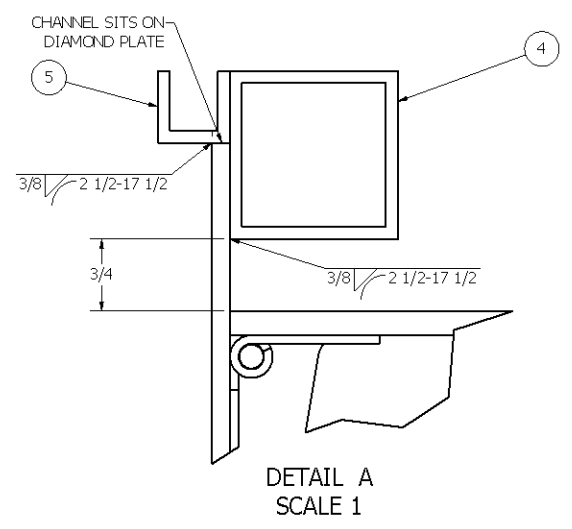

DRAWN narosenberg	5/29/2008	FIRST 200 Bedford Street, Manchester, NH 03101 (603) 666-3906 -- FAX (603) 666-3907
CHECKED dfoster	8/12/2008	
UNLESS OTHERWISE SPECIFIED		TITLE
FRAC.	+/- 1/32	End Panel
.00	+/- .01	SIZE DWG NO
.000	+/- .005	D FE-00004
ANGULAR	+/- .25 Deg.	SCALE
		SHEET 1 OF 3

8 7 6 5 4 3 2 1

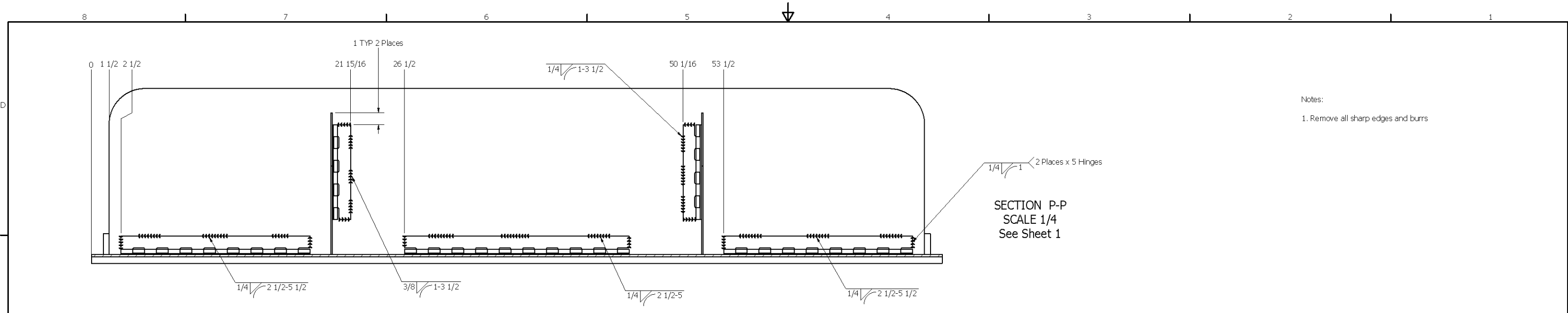

Notes:
1. Remove all sharp edges and burrs

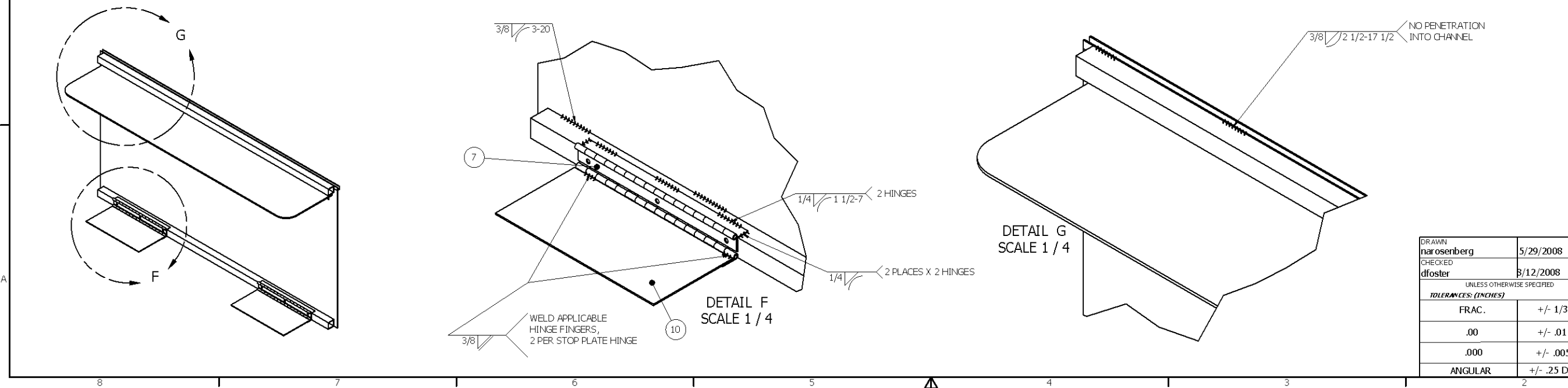
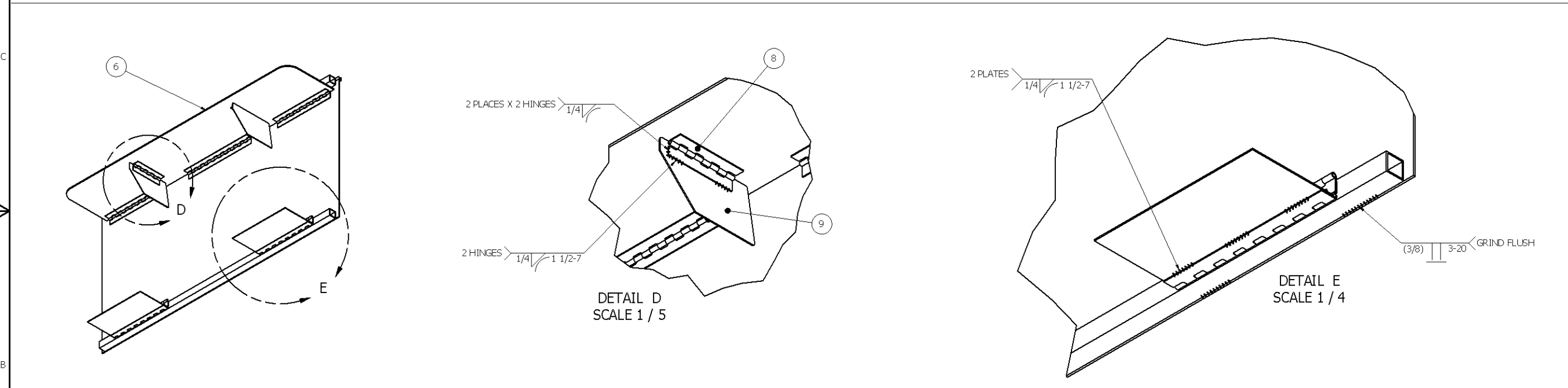

DRAWN narosenberg	5/29/2008	FIRST 200 Bedford Street, Manchester, NH 03101 (603) 666-3906 -- FAX (603) 666-3907	
CHECKED dfoster	8/12/2008		
UNLESS OTHERWISE SPECIFIED		TITLE End Panel	
TOLERANCES: (INCHES)		SIZE D	DWG NO FE-00004
FRAC.	+/- 1/32	REV 1	
.00	+/- .01		
.000	+/- .005		
ANGULAR	+/- .25 Deg.	SCALE	SHEET 2 OF 3

RESOURCE	QTY.	DESCRIPTION	LENGTH	PART NO.
1		3/16 Aluminum Diamond Plate		
2		Hinge, Aluminum 3" x .09", 1/4" Pin		
3		1 3/4" x 1 3/4" x 1/8" Square 6061 Aluminum Tubing		
4		3/4" x 3/4" x 1/8" 6061 Aluminum 'U' Channel		
5		1/4" 6061 Aluminum Plate		
6		1/8" 6061 Aluminum Plate		

Notes:
1. Remove all sharp edges and burrs

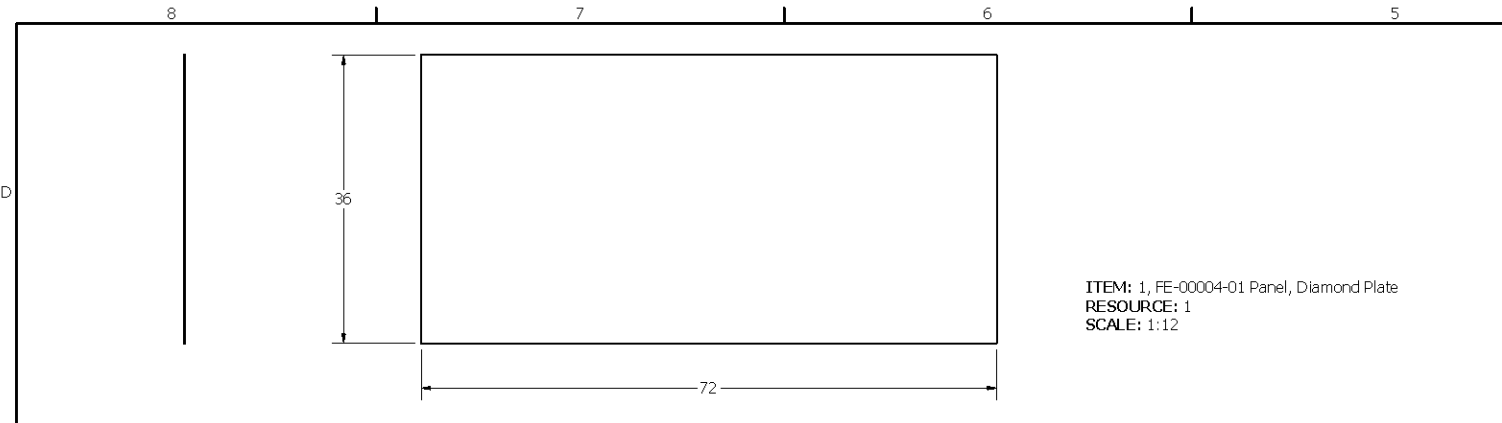

ITEM: 1, FE-00004-01 Panel, Diamond Plate
RESOURCE: 1
SCALE: 1:12

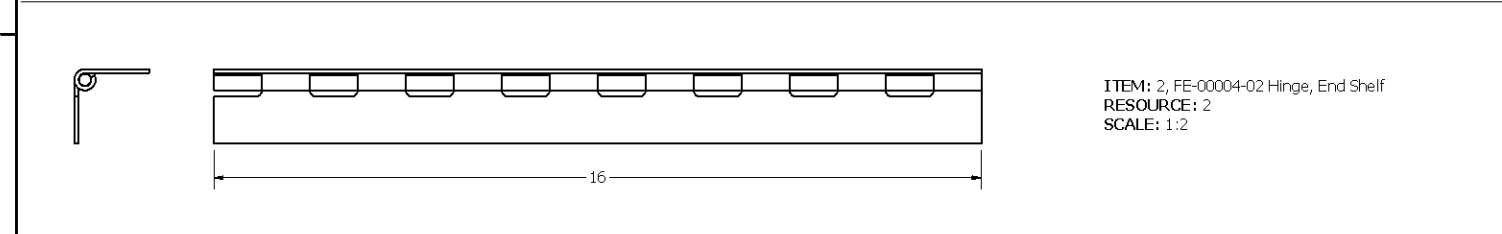

ITEM: 2, FE-00004-02 Hinge, End Shelf
RESOURCE: 2
SCALE: 1:2

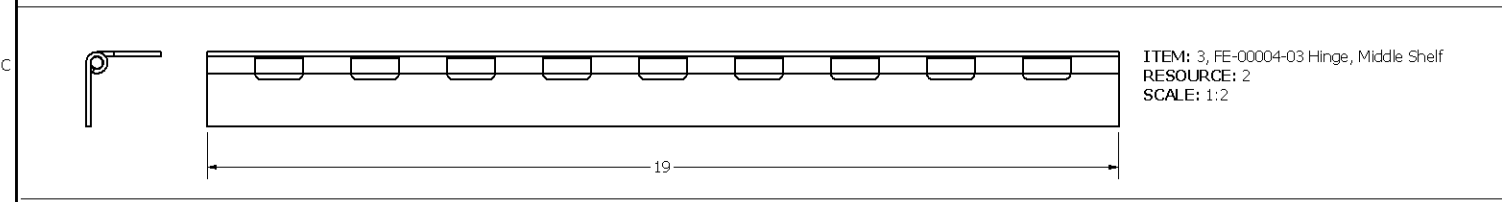

ITEM: 3, FE-00004-03 Hinge, Middle Shelf
RESOURCE: 2
SCALE: 1:2

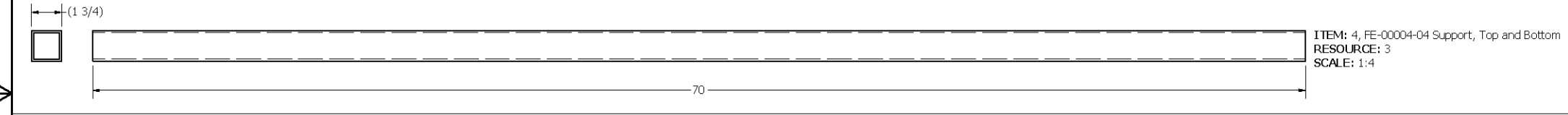

ITEM: 4, FE-00004-04 Support, Top and Bottom
RESOURCE: 3
SCALE: 1:4

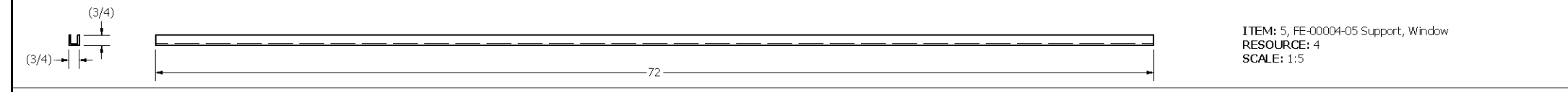

ITEM: 5, FE-00004-05 Support, Window
RESOURCE: 4
SCALE: 1:5

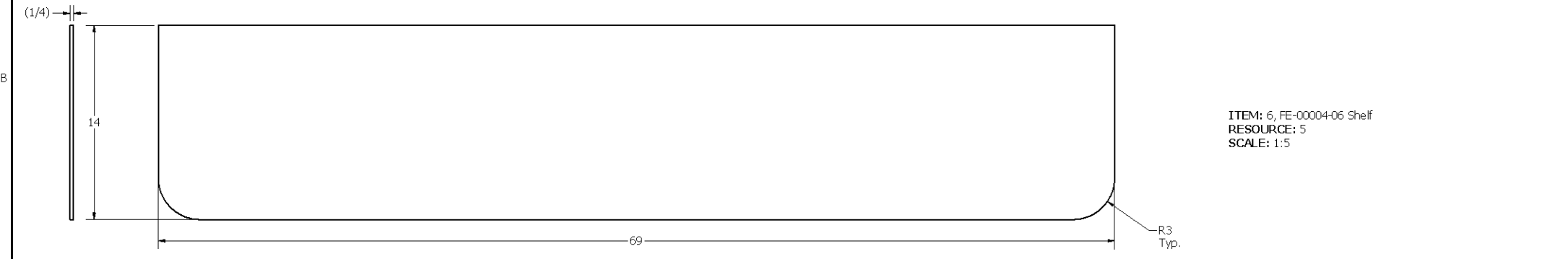

ITEM: 6, FE-00004-06 Shelf
RESOURCE: 5
SCALE: 1:5

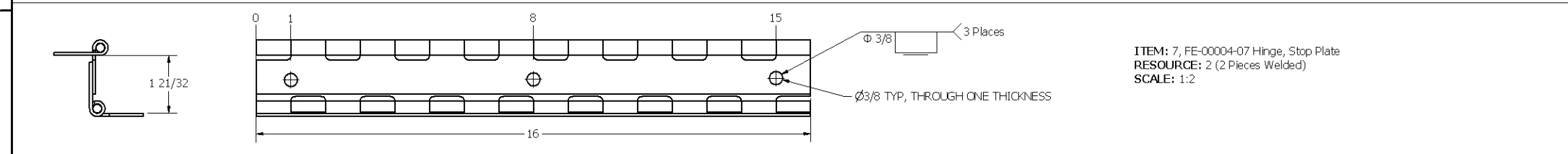

ITEM: 7, FE-00004-07 Hinge, Stop Plate
RESOURCE: 2 (2 Pieces Welded)
SCALE: 1:2

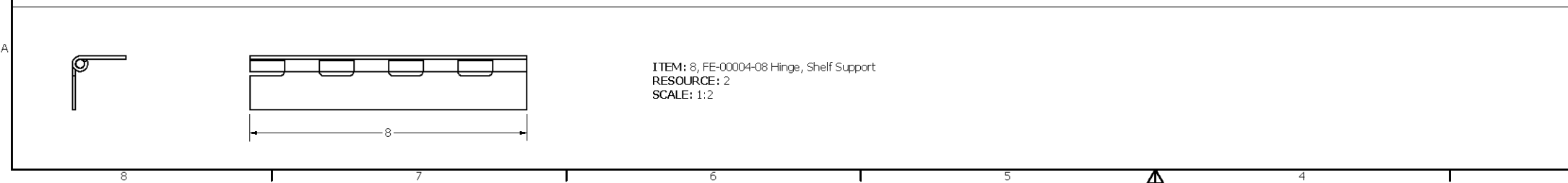

ITEM: 8, FE-00004-08 Hinge, Shelf Support
RESOURCE: 2
SCALE: 1:2

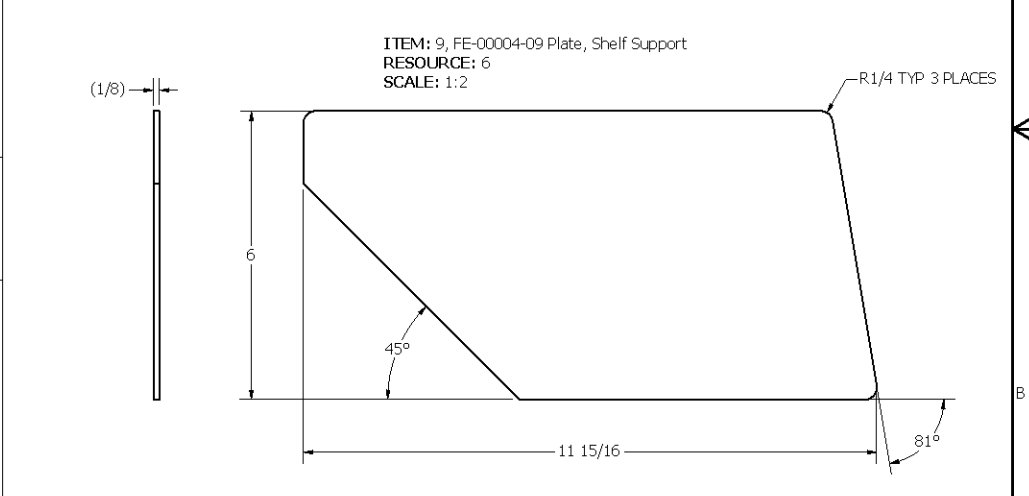

ITEM: 9, FE-00004-09 Plate, Shelf Support
RESOURCE: 6
SCALE: 1:2

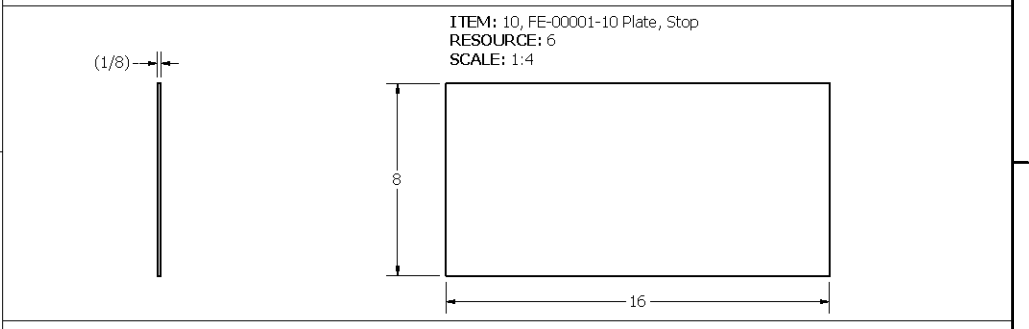

ITEM: 10, FE-00001-10 Plate, Stop
RESOURCE: 6
SCALE: 1:4

DRAWN narosenberg	5/29/2008	FIRST 200 Bedford Street, Manchester, NH 03101 (603) 666-3906 -- FAX (603) 666-3907	
CHECKED dfoster	8/12/2008		
UNLESS OTHERWISE SPECIFIED		TITLE End Panel	
TOLERANCES: (INCHES)		SIZE	DWG NO
FRAC.	+/- 1/32	D	FE-00004
.00	+/- .01	SCALE	REV 1
.000	+/- .005		
ANGULAR	+/- .25 Deg.	SHEET 3 OF 3	

REVISION HISTORY				
ZONE	REV	DESCRIPTION	DATE	APPROVED
	1	Redrawn	5/28/2008	narosenberg

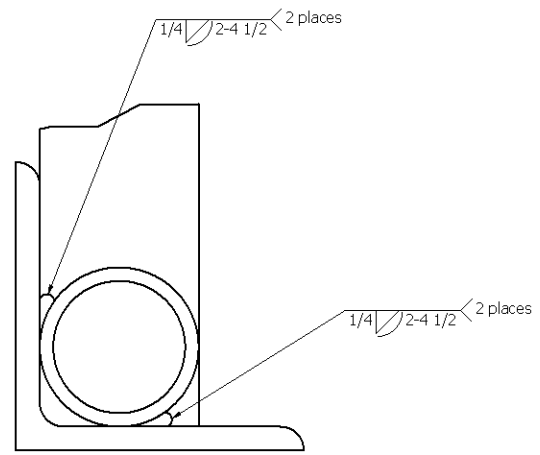
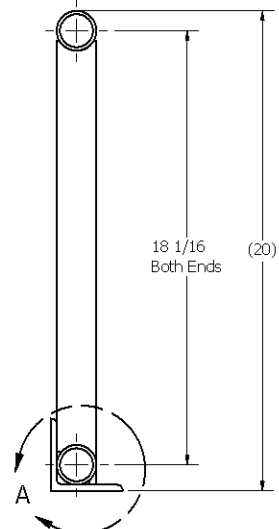
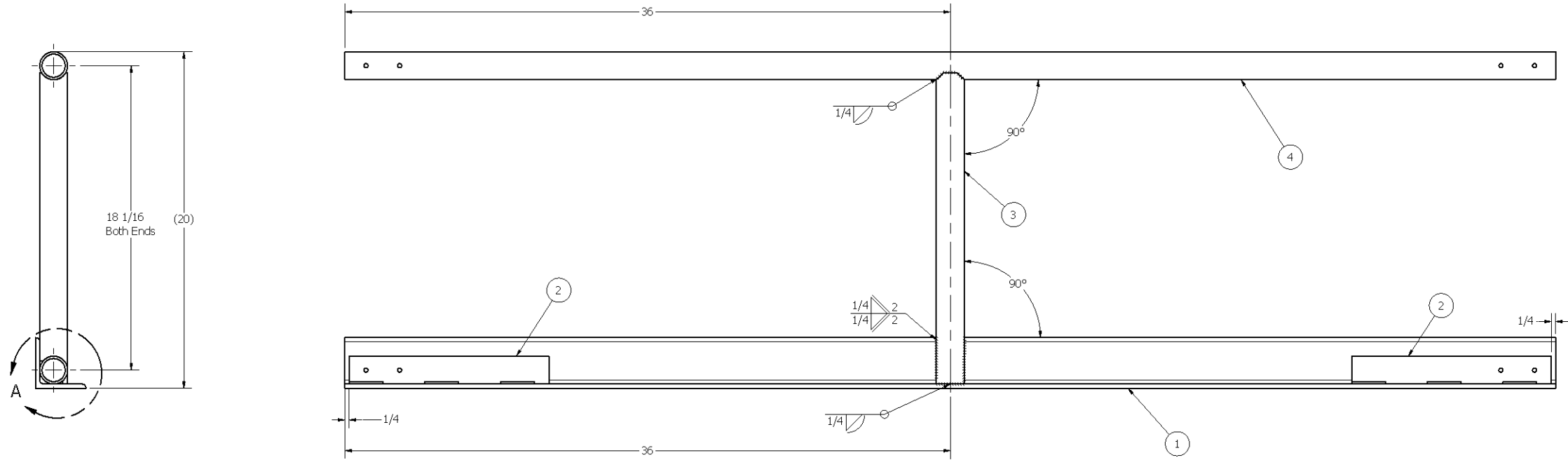

DETAIL A
SCALE 1 : 1

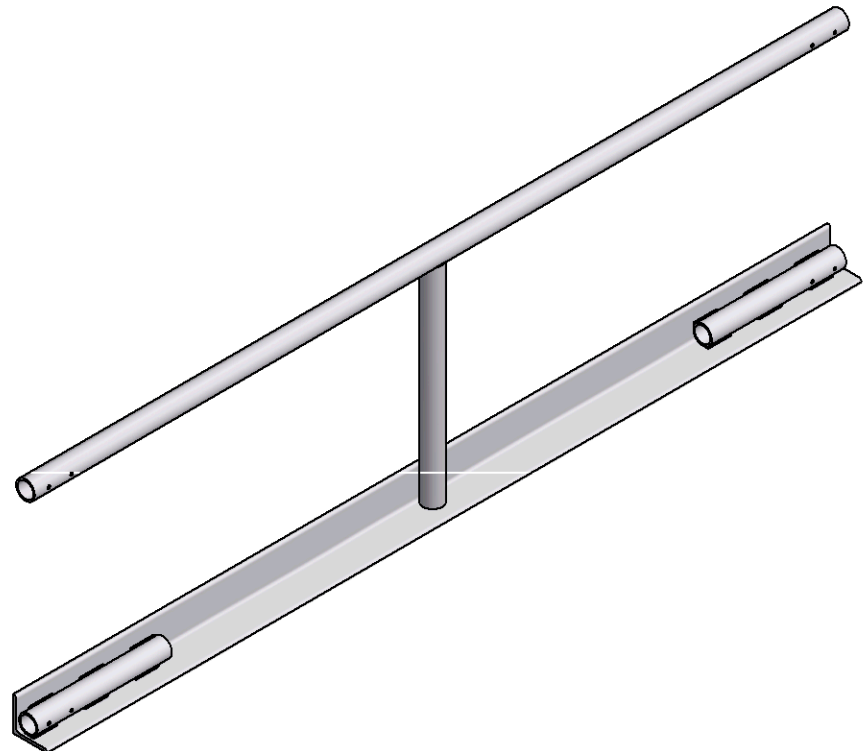

RESOURCES		
RESOURCE	QTY.	DESCRIPTION
1	6'	3" X 3" X 1/4" 6061-T6 ALUMINUM ANGLE
2	10'	1 1/4" SCHEDULE 40 6061-T6 ALUMINUM PIPE

Parts List			
ITEM	QTY	PART NUMBER	DESCRIPTION
1	1	FE-00005-01	Bottom Rail
2	2	FE-00005-02	Connecting Tube
3	1	FE-00005-03	Vertical Support
4	1	FE-00005-04	Top Rail

DRAWN dfoster	5/28/2008	FIRST 200 Bedford Street, Manchester, NH 03101 (603) 666-3906 -- FAX (603) 666-3907	
CHECKED			
UNLESS OTHERWISE SPECIFIED		TITLE	
TOLERANCES: (INCHES)		FIELD RAIL	
FRAC.	+/- 1/32	SIZE	DWG NO
.00	+/- .01	D	FE-00005
.000	+/- .005	SCALE	REV 1
ANGULAR	+/- .25 Deg.	SHEET 1 OF 2	

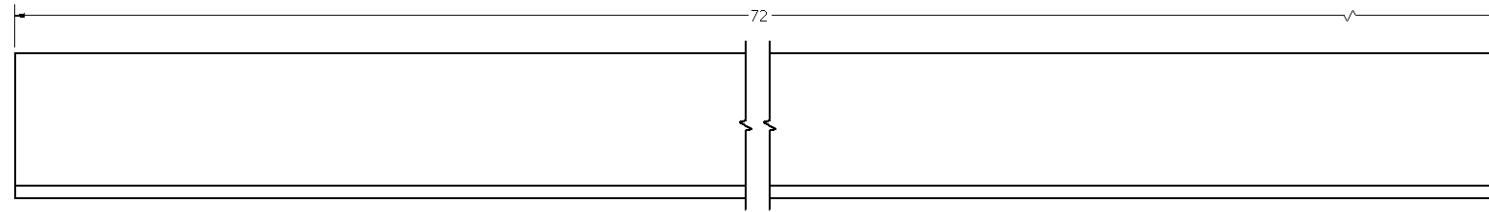
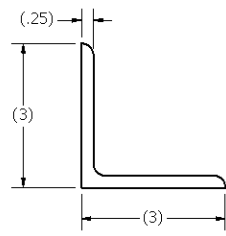

Item: FE-00005-0 Bottom Rail
Resource: 1
Scale: 1/2

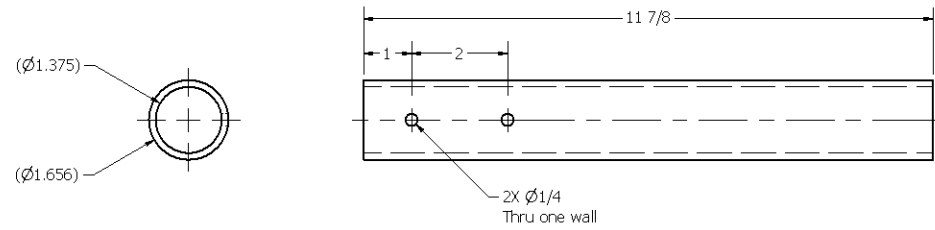

Item: FE-00005-02 Connecting Tube
Resource: 2
Scale: 1/2

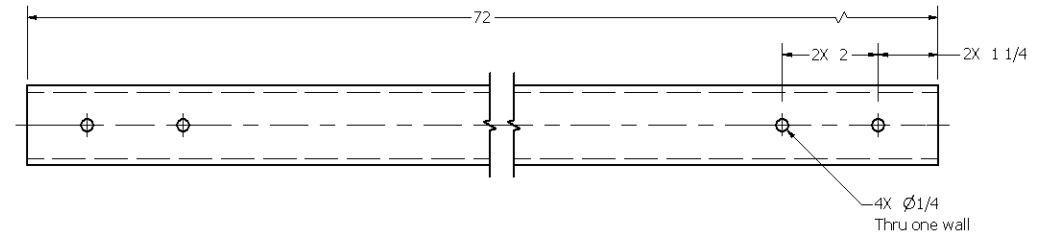
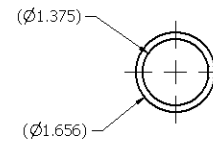

Item: FE-00005-04 Top Rail
Resource: 2
Scale: 1/2

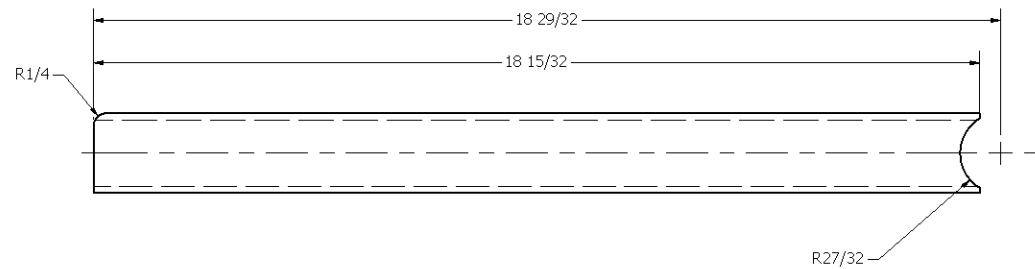
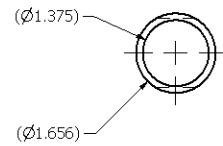
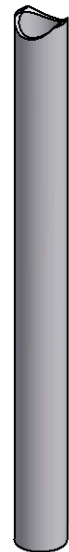

Item: FE-00005-03 Vertical Support
Resource: 2
Scale: 1/2

DRAWN dfoster	5/28/2008	FIRST 200 Bedford Street, Manchester, NH 03101 (603) 666-3906 -- FAX (603) 666-3907	
CHECKED			
UNLESS OTHERWISE SPECIFIED		TITLE	
TOLERANCES: (INCHES)		FIELD RAIL	
FRAC.	+/- 1/32	SIZE	DWG NO
.00	+/- .01	D	FE-00005
.000	+/- .005	SCALE	REV
ANGULAR	+/- .25 Deg.		1
		SHEET 2 OF 2	

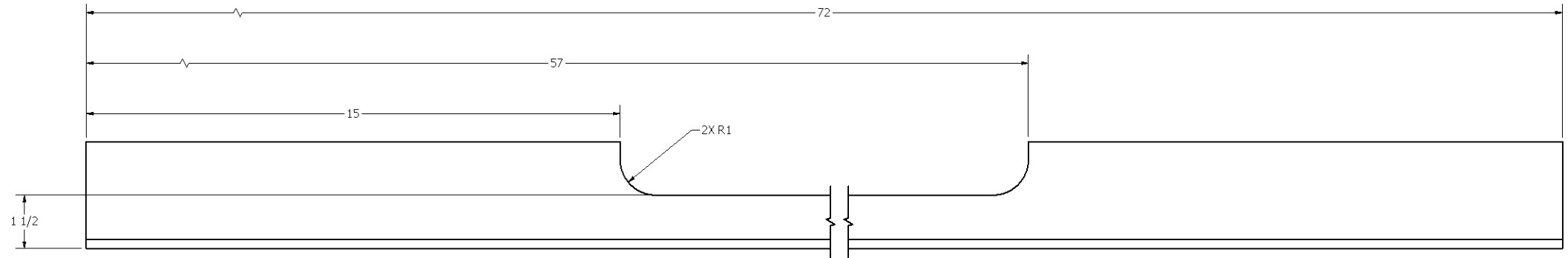
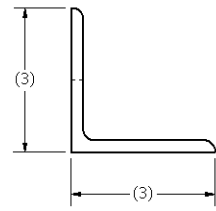

Item: 1, FE-00006-01 Bottom Rail
 Resource: 1
 Scale: 1/2

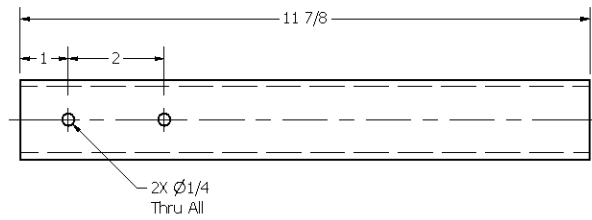
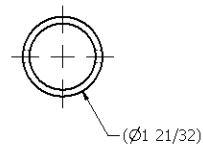

Item: 2, FE-00006-02 Connecting Tube
 Resource: 2
 Scale: 1/2

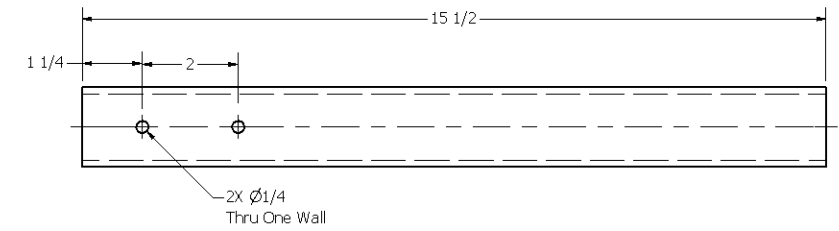
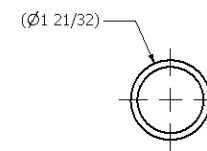

Item: 3, FE-00006-03 Upper Rail "A"
 Resource: 2
 Scale: 1/2

DRAWN dfoster	8/5/2008	FIRST 200 Bedford Street, Manchester, NH 03101 (603) 666-3906 -- FAX (603) 666-3907	
CHECKED narosenberg	8/13/2008		
UNLESS OTHERWISE SPECIFIED		TITLE	
TOLERANCES: (INCHES)		Field Gate - Weldment	
FRAC.	+/- 1/32	SIZE	DWG NO
.00	+/- .01	D	FE-00006
.000	+/- .005	SCALE	REV
ANGULAR	+/- .25 Deg.		1
		SHEET 2 OF 3	

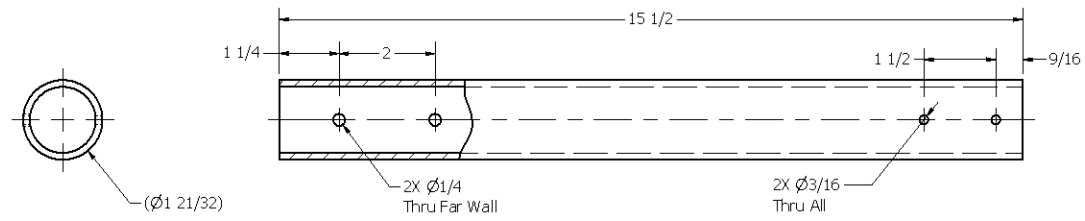

Item: 4, FE-00006-05 Upper Rail "B"
Resource: 2
Scale: 1/2

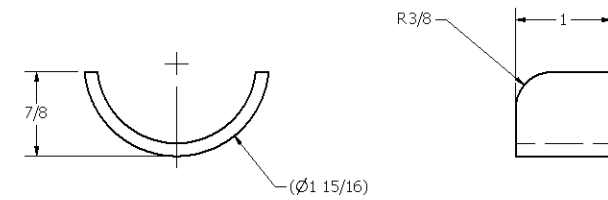

Item: 5, FE-00006-08 Gate Stop
Resource: 3
Scale: 1/1

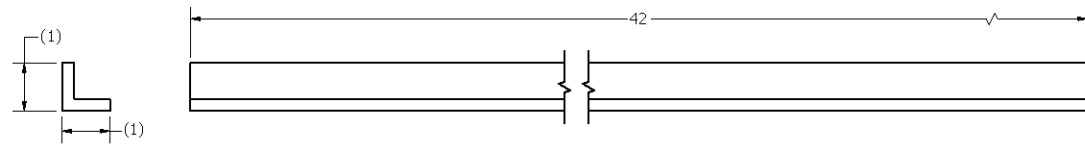

Item: 6, FE-00006-09 Ramp Stop
Resource: 4
Scale: 1/2

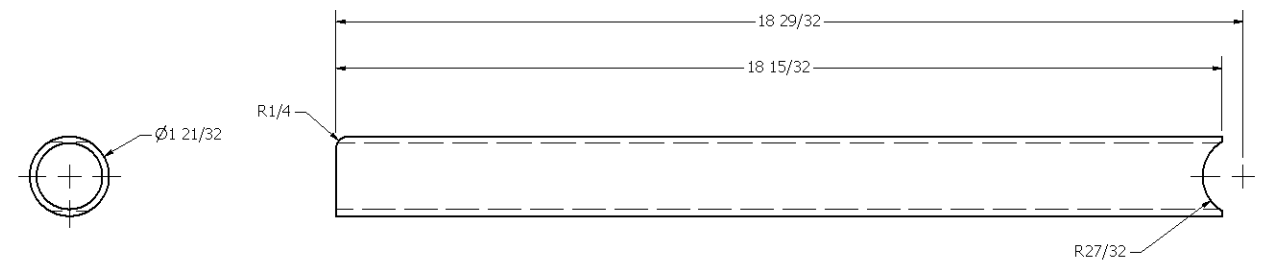

Item: 7, FE-00006-10 Vertical Support
Resource: 2
Scale: 1/2

DRAWN dfoster	8/5/2008	FIRST 200 Bedford Street, Manchester, NH 03101 (603) 666-3906 -- FAX (603) 666-3907		
CHECKED narosenberg	8/13/2008			
UNLESS OTHERWISE SPECIFIED		TITLE Field Gate - Weldment		
TOLERANCES: (INCHES)				
FRAC.	+/- 1/32	SIZE	DWG NO	REV
.00	+/- .01	D	FE-00006	1
.000	+/- .005	SCALE	SHEET 3 OF 3	
ANGULAR	+/- .25 Deg.			

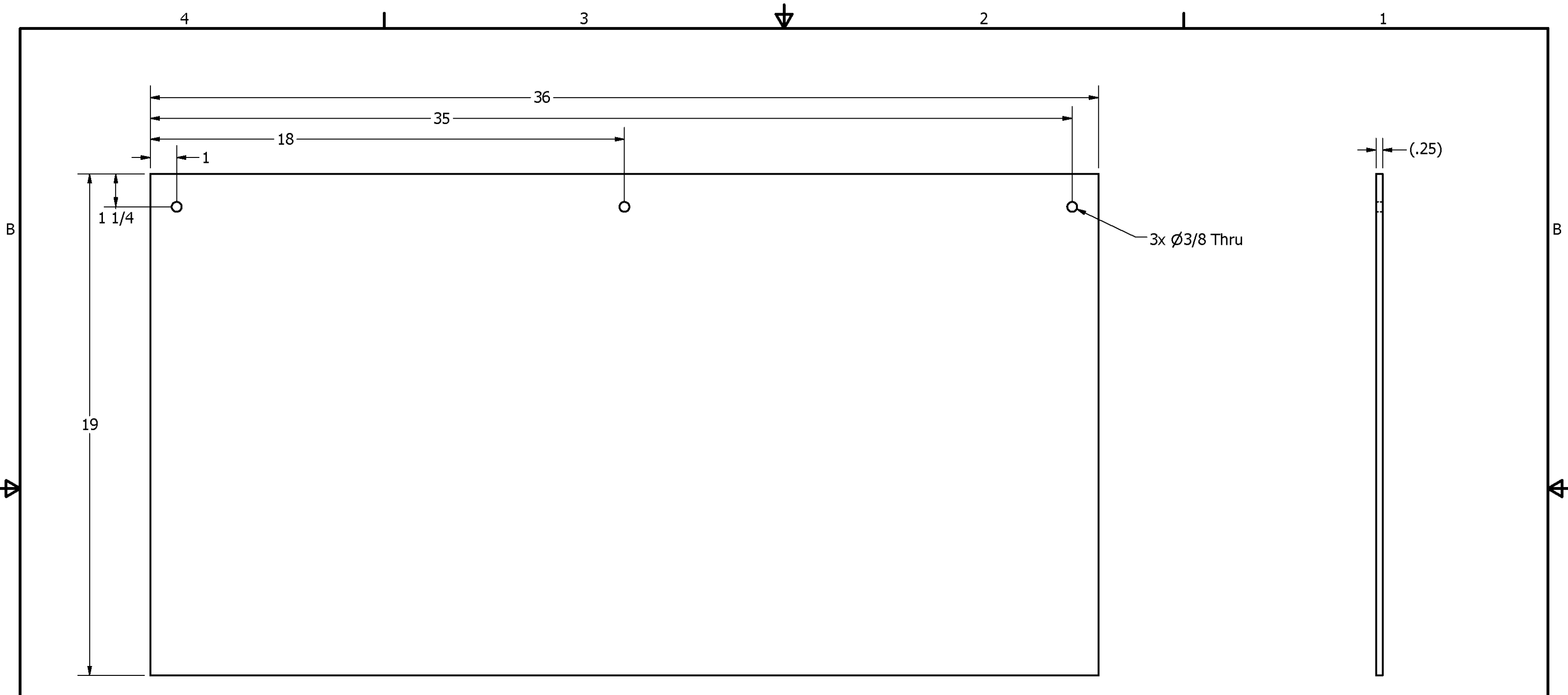

3x $\phi 3/8$ Thru

(.25)

- Notes:
 1. Material: 1/4" Clear Polycarbonate
 2. Please remove all sharp edges

DRAWN	mcyr	6/2/2008	FIRST 200 Bedford Street, Manchester, NH 03101 (603) 666-3906 -- FAX (603) 666-3907	
CHECKED				
UNLESS OTHERWISE SPECIFIED			TITLE Field Plastic "A"	
TOLERANCES: (INCHES)				
FRAC.		+/- 1/32		
.00		+/- .01		
.000		+/- .005	SIZE	DWG NO
ANGULAR		+/- .25 Deg.	B	FE-00008
			SCALE	REV
				SHEET 1 OF 1

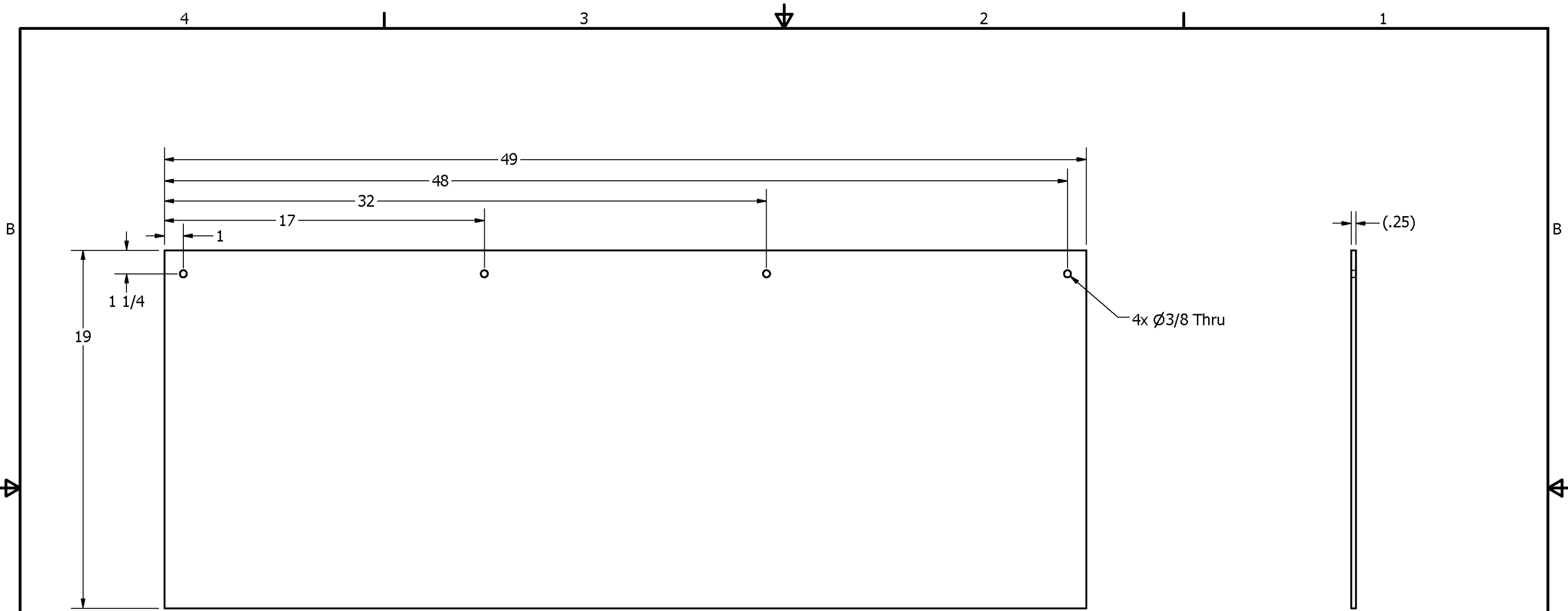

4x ϕ 3/8 Thru

(.25)

- Notes:
 1. Material: 1/4" Clear Polycarbonate.
 2. Remove all sharp edges.

DRAWN	mcyr	6/2/2008	FIRST 200 Bedford Street, Manchester, NH 03101 (603) 666-3906 -- FAX (603) 666-3907		
CHECKED					
UNLESS OTHERWISE SPECIFIED			TITLE Field Plastic "B"		
TOLERANCES: (INCHES)					
FRAC.		+/- 1/32			
.00		+/- .01			
.000		+/- .005	SIZE	DWG NO	REV
ANGULAR		+/- .25 Deg.	B	FE-00009	
			SCALE	SHEET 1 OF 1	

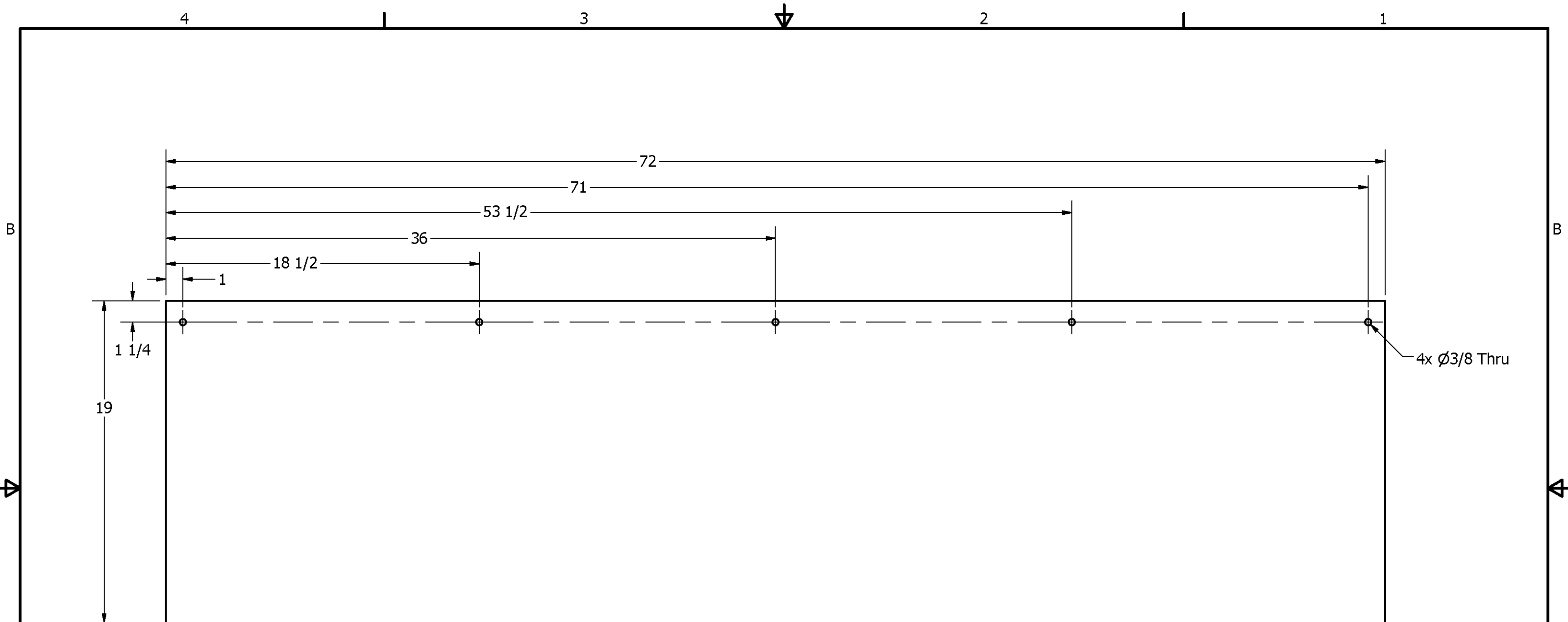

Material: 1/4" Thick Polycarbonate Sheet

DRAWN mcyr	6/2/2008	FIRST 200 Bedford Street, Manchester, NH 03101 (603) 666-3906 -- FAX (603) 666-3907		
CHECKED	1/2/2009			
UNLESS OTHERWISE SPECIFIED		TITLE Field Plastic "C"		
TOLERANCES: (INCHES)				
FRAC.	+/- 1/32			
.00	+/- .01			
.000	+/- .005	SIZE B	DWG NO FE-00010	REV
ANGULAR	+/- .25 Deg.	SCALE	SHEET 1 OF 1	

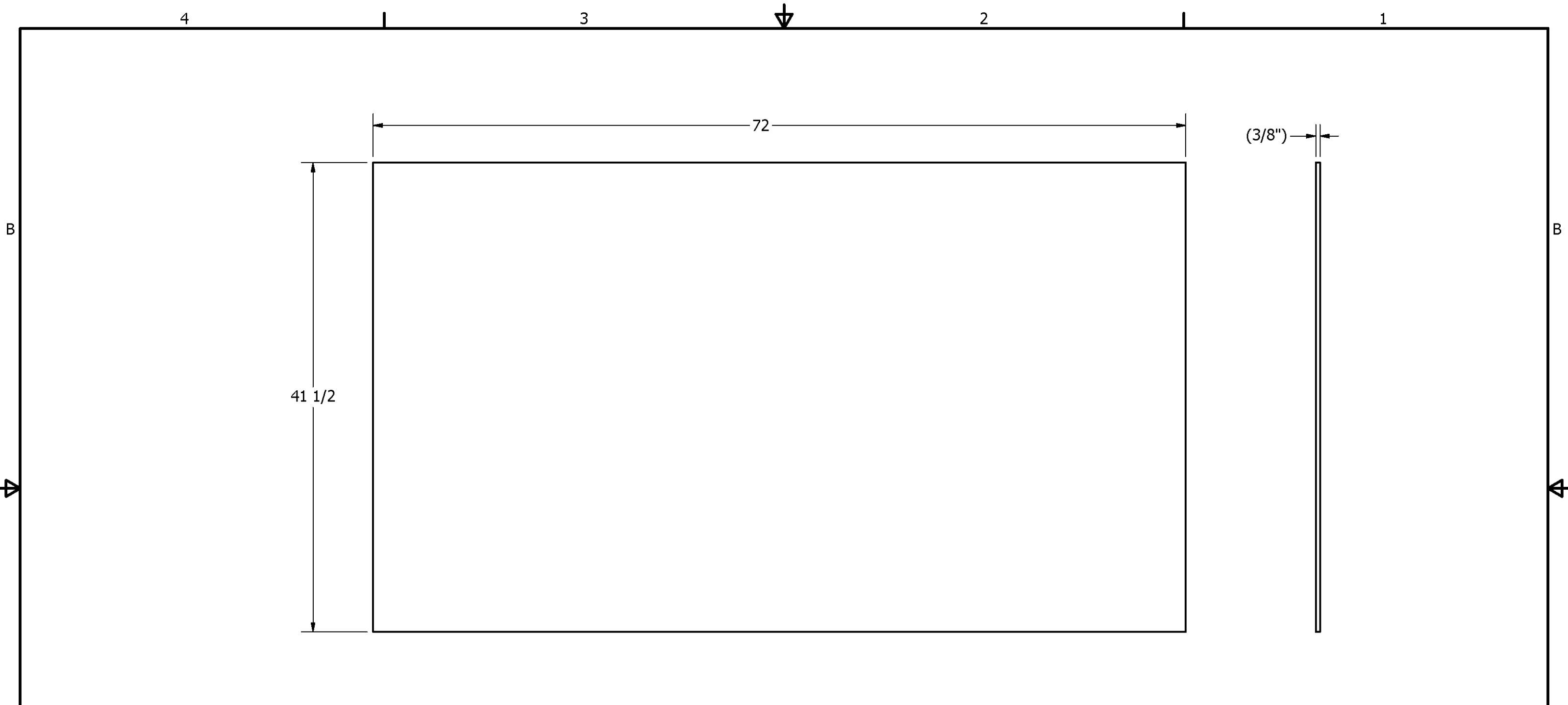

DRAWN mcyr		6/2/2008		FIRST 200 Bedford Street, Manchester, NH 03101 (603) 666-3906 -- FAX (603) 666-3907	
CHECKED dfoster		1/2/2009			
UNLESS OTHERWISE SPECIFIED				TITLE Drivers Station Acrylic	
TOLERANCES: (INCHES)					
FRAC.	+/- 1/32				
.00	+/- .01			SIZE	DWG NO
.000	+/- .005			B	FE-00012
ANGULAR	+/- .25 Deg.			SCALE	REV
				SHEET 1 OF 1	

Material: 3/8" Thick Acrylic Sheet

REVISION HISTORY				
ZONE	REV	DESCRIPTION	DATE	APPROVED
	1	Redrawn	5/27/2008	narosenberg

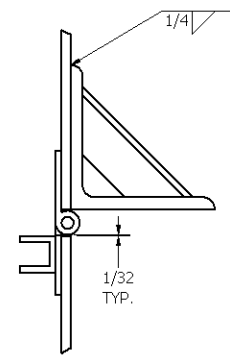

DETAIL B
SCALE 1 / 2

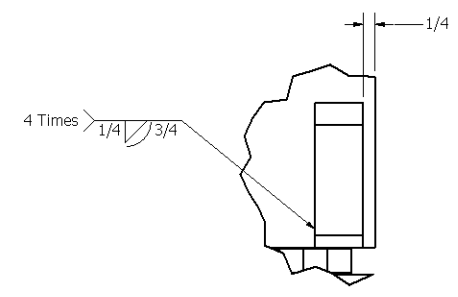

DETAIL A
SCALE 1 / 2

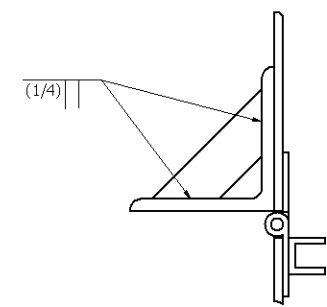

DETAIL C
SCALE 1 / 2

RESOURCES		
RESOURCE	QTY.	DESCRIPTION
1	AR	3/16" 3003 ALUMINUM DIAMOND PLATE
2	39"	3" ALUMINUM HINGE, 1/4" PIN
3	39"	3/4" X 3/4" X 1/8" 6061-T6 ALUMINUM CHANNEL
4	1"	3" X 3" X 1/4" 6061-T6 ALUMINUM ANGLE
5	4"	1" X 1" X 1/8" 6061-T6 ALUMINUM ANGLE

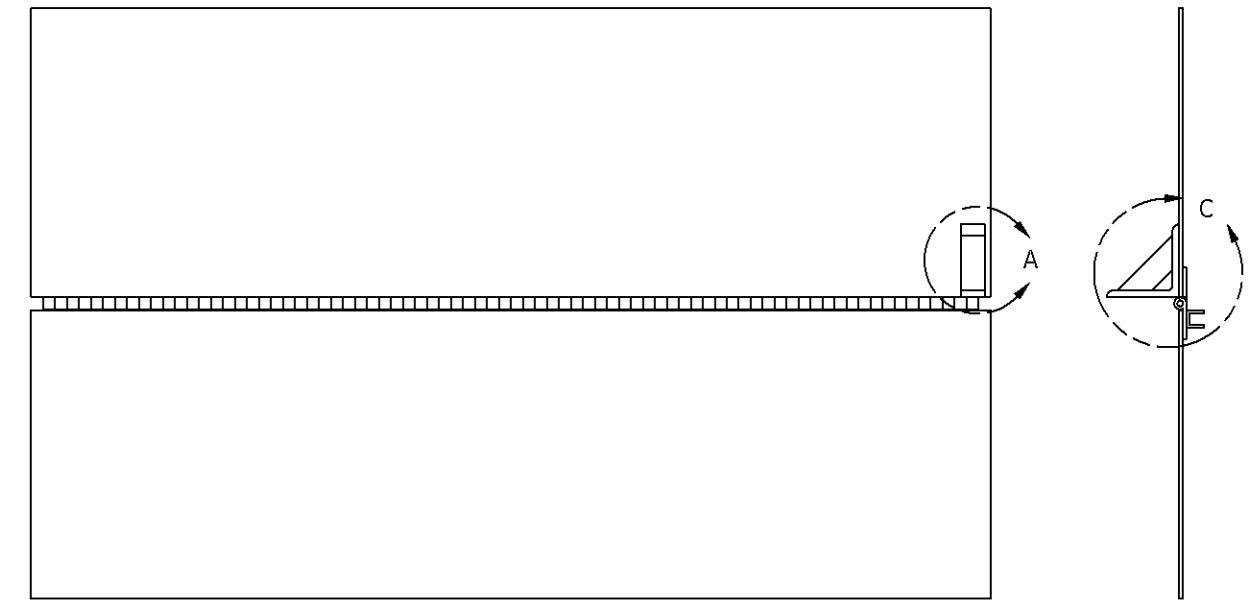
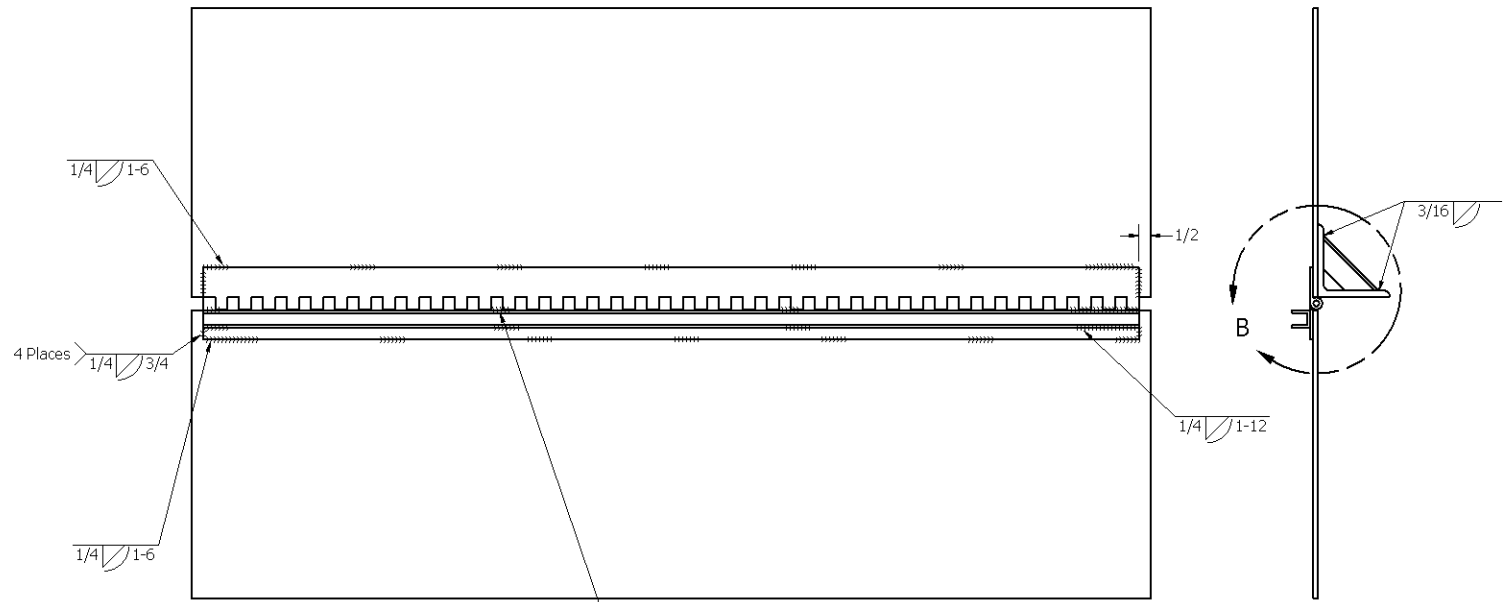

1/4 x 3/4-12 welds should be centered on fingers of hinge.

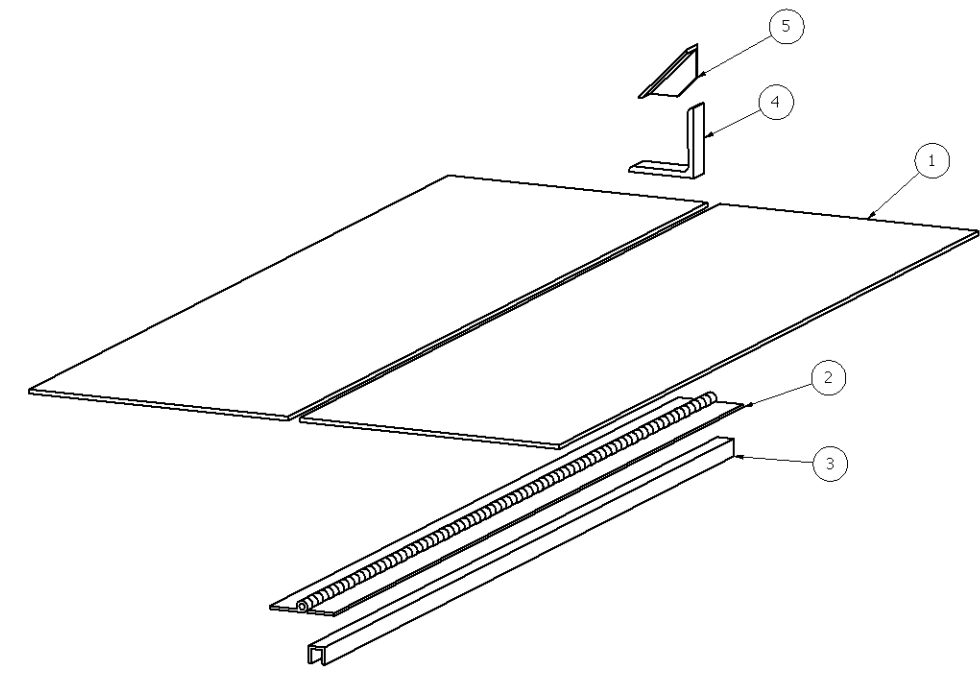
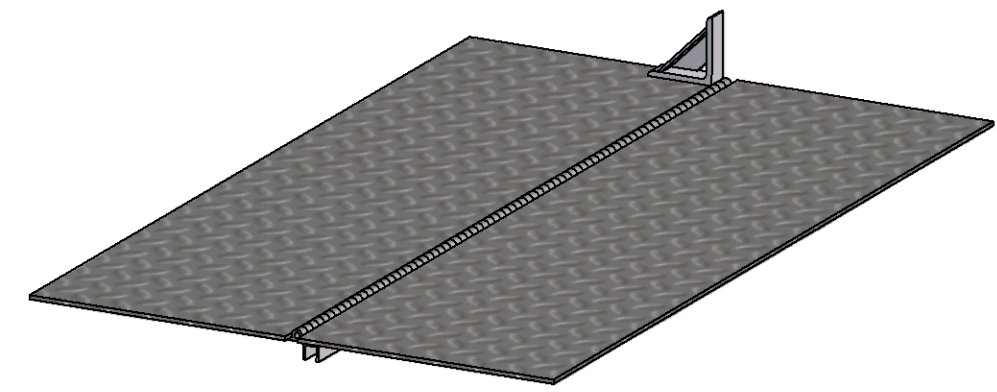

Parts List			
ITEM	QTY	PART NUMBER	DESCRIPTION
1	2	FE-00014-01	Ramp Plate
2	1	FE-00014-02	Hinge
3	1	FE-00014-03	Channel
4	1	FE-00014-04	Kick Angle
5	1	FE-00014-05	Gusset

DRAWN dfoster	5/27/2008	FIRST 200 Bedford Street, Manchester, NH 03101 (603) 666-3906 -- FAX (603) 666-3907
CHECKED narosenberg	3/4/2008	
UNLESS OTHERWISE SPECIFIED		TITLE Field Entry Ramp
FRAC.	+/- 1/32	SIZE DWG NO
.00	+/- .01	D FE-00014
.000	+/- .005	SCALE
ANGULAR	+/- .25 Deg.	SHEET 1 OF 2
		REV 1

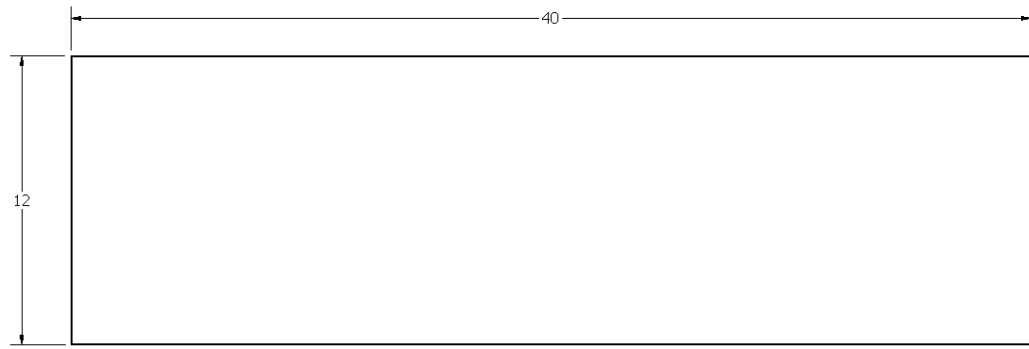

ITEM: 1, FE-00014-01 Ramp Plate
 RESOURCE: 1
 SCALE: 1/4

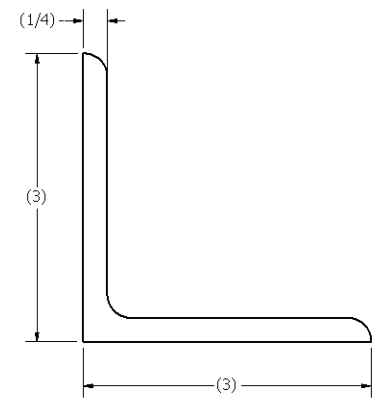
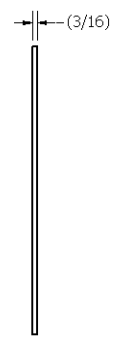

ITEM: 1, FE-00014-04 Kick Angle
 RESOURCE: 4
 SCALE: 1/1

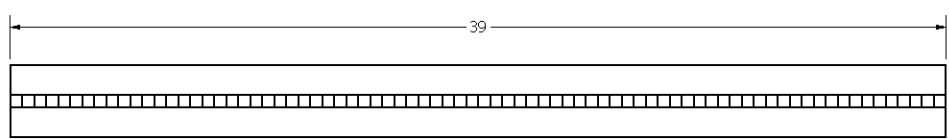
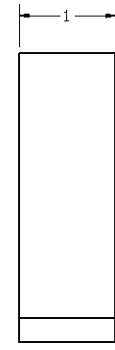

ITEM: 1, FE-00014-02 Hinge
 RESOURCE: 2
 SCALE: 1/4

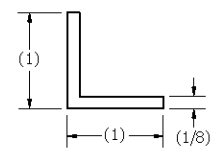
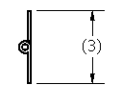

ITEM: 1, FE-00014-05 Gusset
 RESOURCE: 5
 SCALE: 1/1

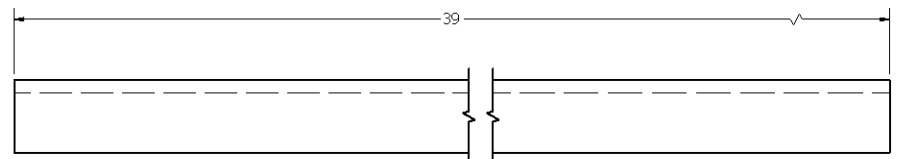
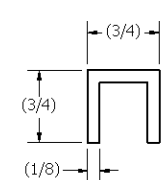
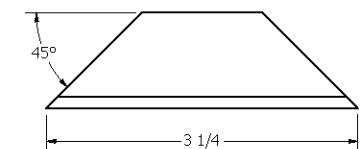

ITEM: 1, FE-00014-03 Channel
 RESOURCE: 3
 SCALE: 1/1

Note: Remove all sharp edges.

DRAWN dfoster	5/27/2008	FIRST 200 Bedford Street, Manchester, NH 03101 (603) 666-3906 -- FAX (603) 666-3907		
CHECKED narosenberg	3/4/2008			
UNLESS OTHERWISE SPECIFIED		TITLE Field Entry Ramp		
TOLERANCES: (INCHES)				
FRAC.	+/- 1/32	SIZE	DWG NO	REV
.00	+/- .01	D	FE-00014	1
.000	+/- .005	SCALE	SHEET 2 OF 2	
ANGULAR	+/- .25 Deg.			

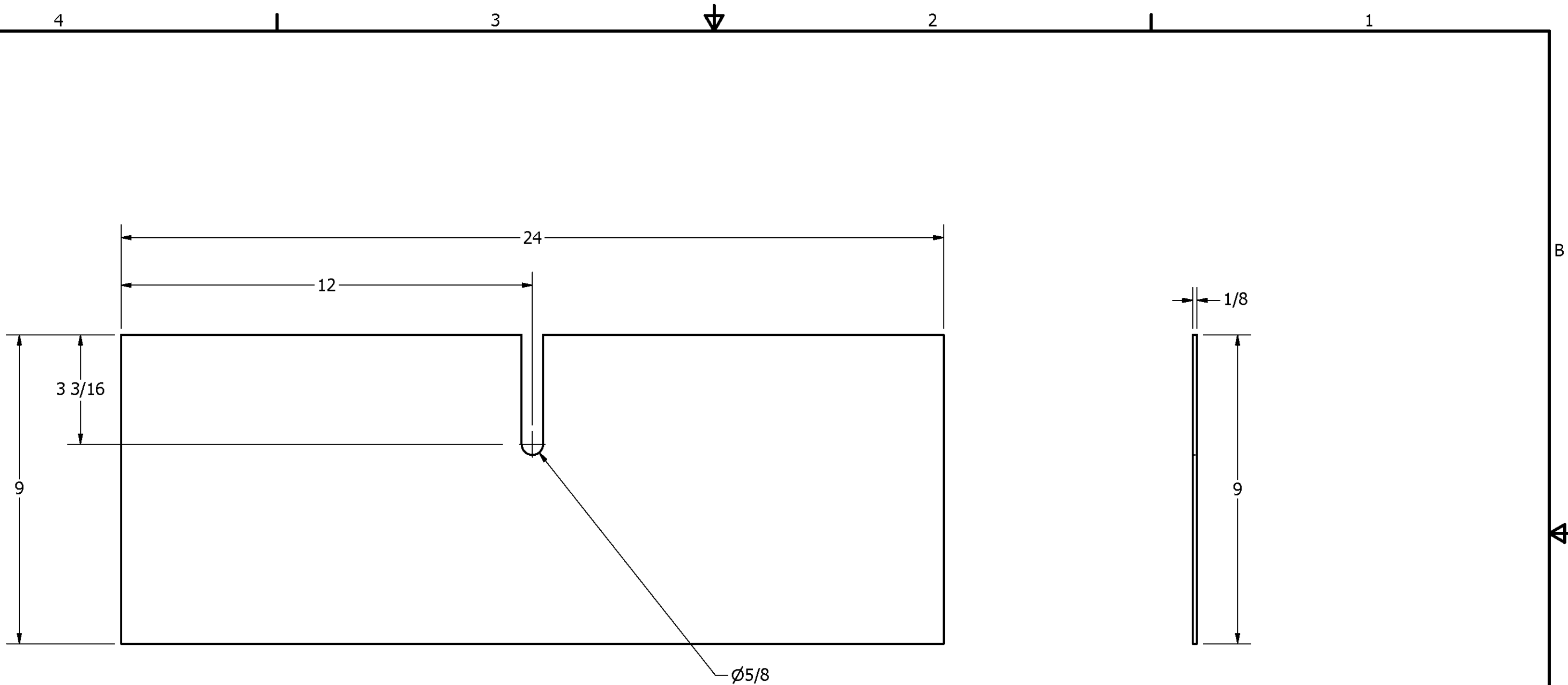

- Notes:
1. Material to be HDPE, Yellow.
 2. Remove all sharp edges

DRAWN dfoster CHECKED		1/2/2009		FIRST 200 Bedford Street, Manchester, NH 03101 (603) 666-3906 -- FAX (603) 666-3907	
UNLESS OTHERWISE SPECIFIED TOLERANCES: (INCHES)					
FRAC.				SIZE	DWG NO
				B	FE-00015
				SCALE	REV
				SHEET 1 OF 1	

REVISION HISTORY				
ZONE	REV	DESCRIPTION	DATE	APPROVED
	1	redrawn	5/30/2008	narosenberg

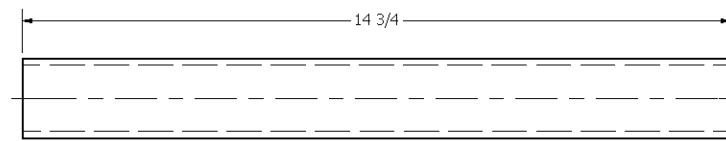
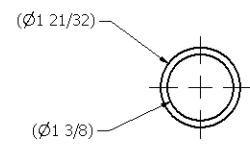
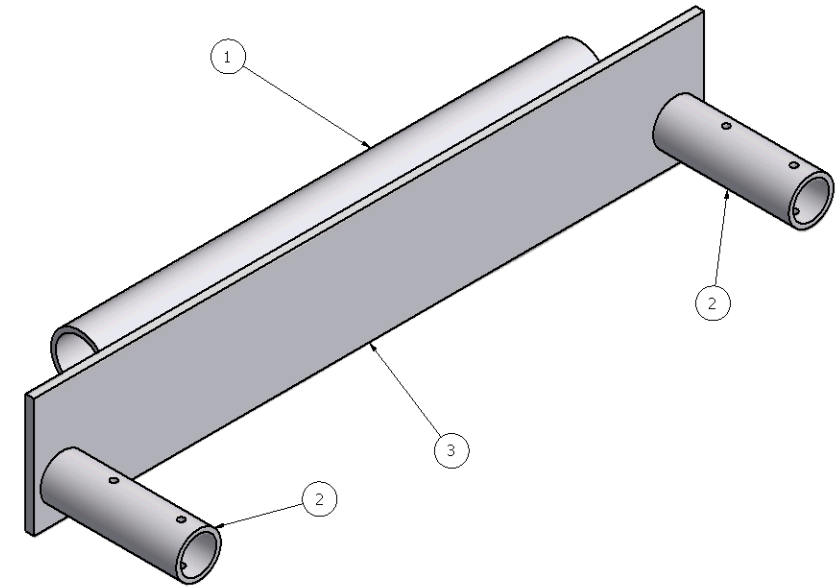
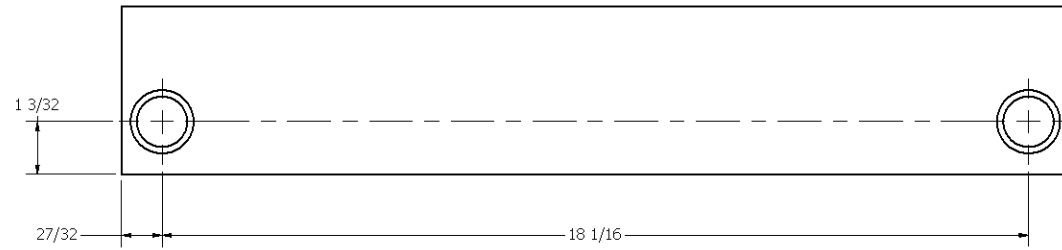
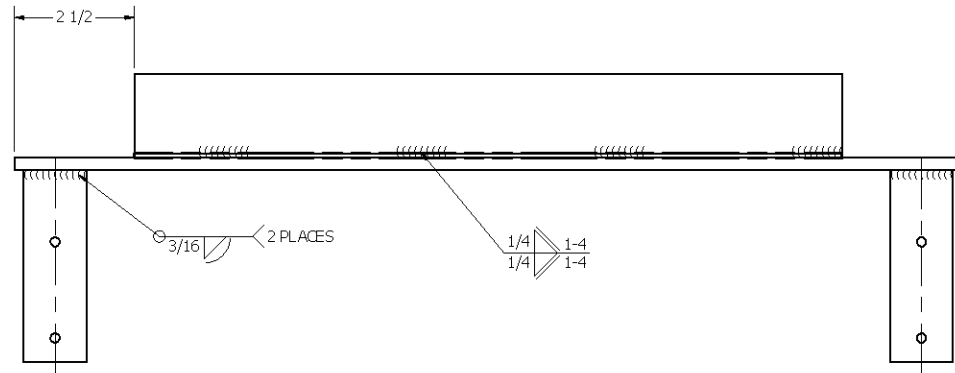
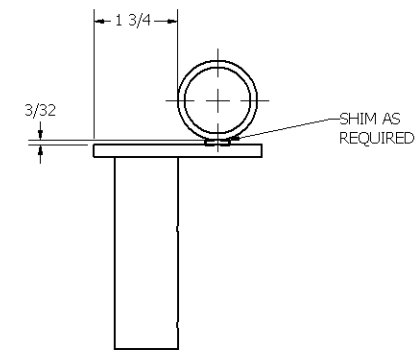

ITEM: 1, FE-00018-01 CONNECTING TUBE
RESOURCE: 1
SCALE: 1/2

RESOURCES		
RESOURCE	QTY.	DESCRIPTION
1	15"	1 1/4" SCHEDULE 40 6061-T6 ALUMINUM PIPE
2	8"	1" SCHEDULE 40 6061-T6 ALUMINUM PIPE
3	20"	3 1/2" X 1/4" 6061-T6 ALUMINUM BAR

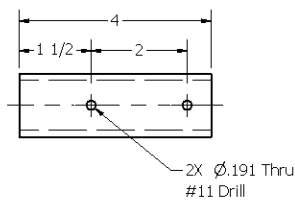
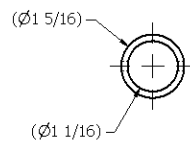

ITEM: 2, FE-00018-02 INSERT TUBE
RESOURCE: 2
SCALE: 1/2

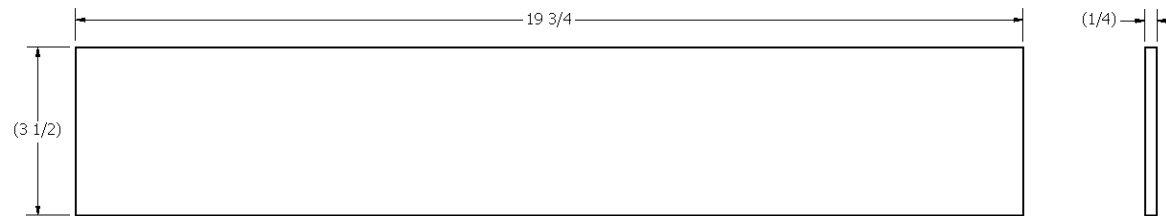

ITEM: 3, FE-00018-03 MOUNTING PLATE
RESOURCE: 3
SCALE: 1/2

Parts List			
ITEM	QTY	PART NUMBER	DESCRIPTION
1	1	FE-00018-01	Connecting Tube
2	2	FE-00018-02	Insert Tube
3	1	FE-00018-03	Mounting Plate

DRAWN dfoster	5/30/2008	FIRST 200 Bedford Street, Manchester, NH 03101 (603) 666-3906 -- FAX (603) 666-3907
CHECKED narosenberg	8/4/2008	
UNLESS OTHERWISE SPECIFIED		TITLE
TOLERANCES: (INCHES)		CORNER CONNECTOR
FRAC.	+/- 1/32	SIZE DWG NO
.00	+/- .01	D FE-00018
.000	+/- .005	SCALE
ANGULAR	+/- .25 Deg.	SHEET 1 OF 1
		REV 1

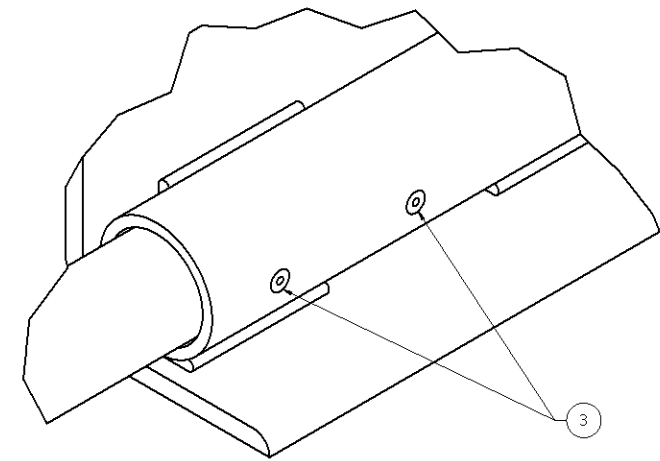
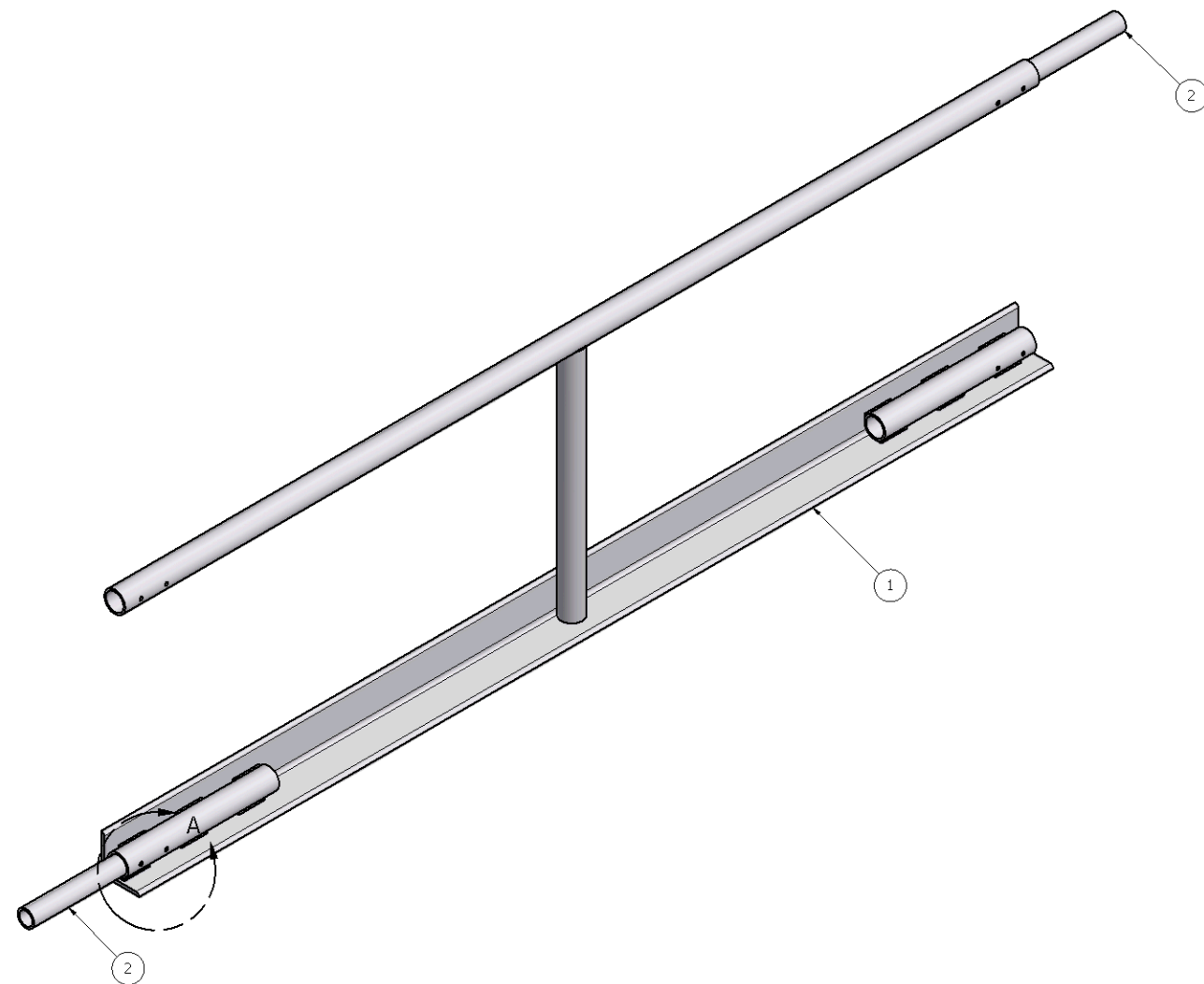
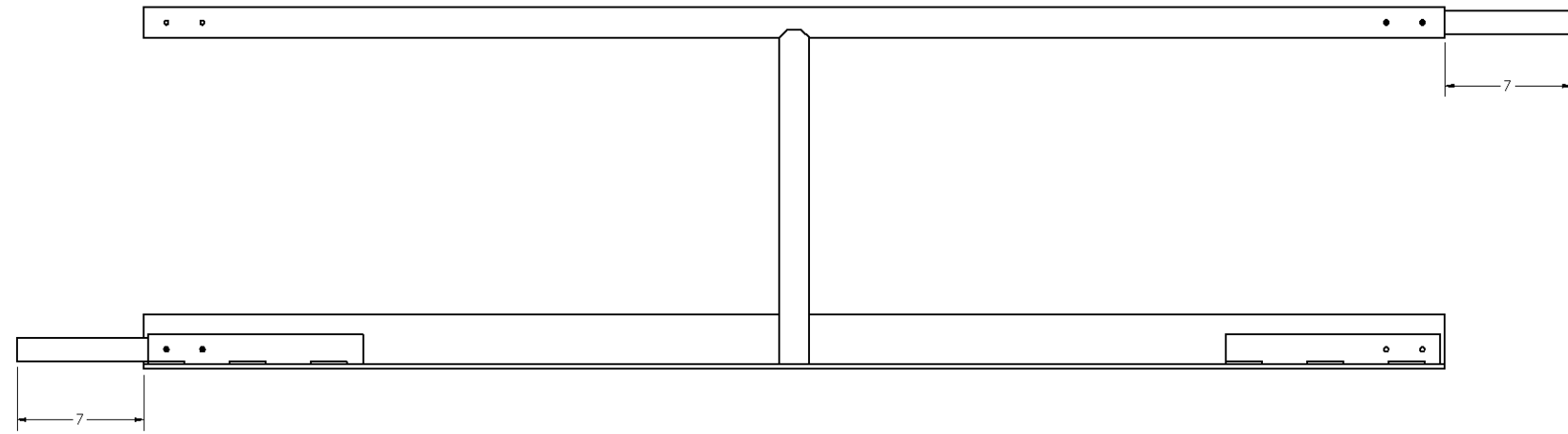

DETAIL A
SCALE 1 : 1

Parts List			
ITEM	QTY	PART NUMBER	DESCRIPTION
1	1	FE-00005	Field Rail
2	2	FE-00026	Connecting Pin
3	4	HW-00010	Pop Rivet 3/16 Dia.

DRAWN dfoster CHECKED UNLESS OTHERWISE SPECIFIED TOLERANCES: (INCHES) FRAC. +/- 1/32 .00 +/- .01 .000 +/- .005 ANGULAR +/- .25 Deg.	6/5/2008 FIRST 200 Bedford Street, Manchester, NH 03101 (603) 666-3906 -- FAX (603) 666-3907 TITLE Field Rail Assy - Mid SIZE DWG NO D FE-00022 SCALE	REV 1 SHEET 1 OF 1
--	--	--------------------------

8 7 6 5 4 3 2 1

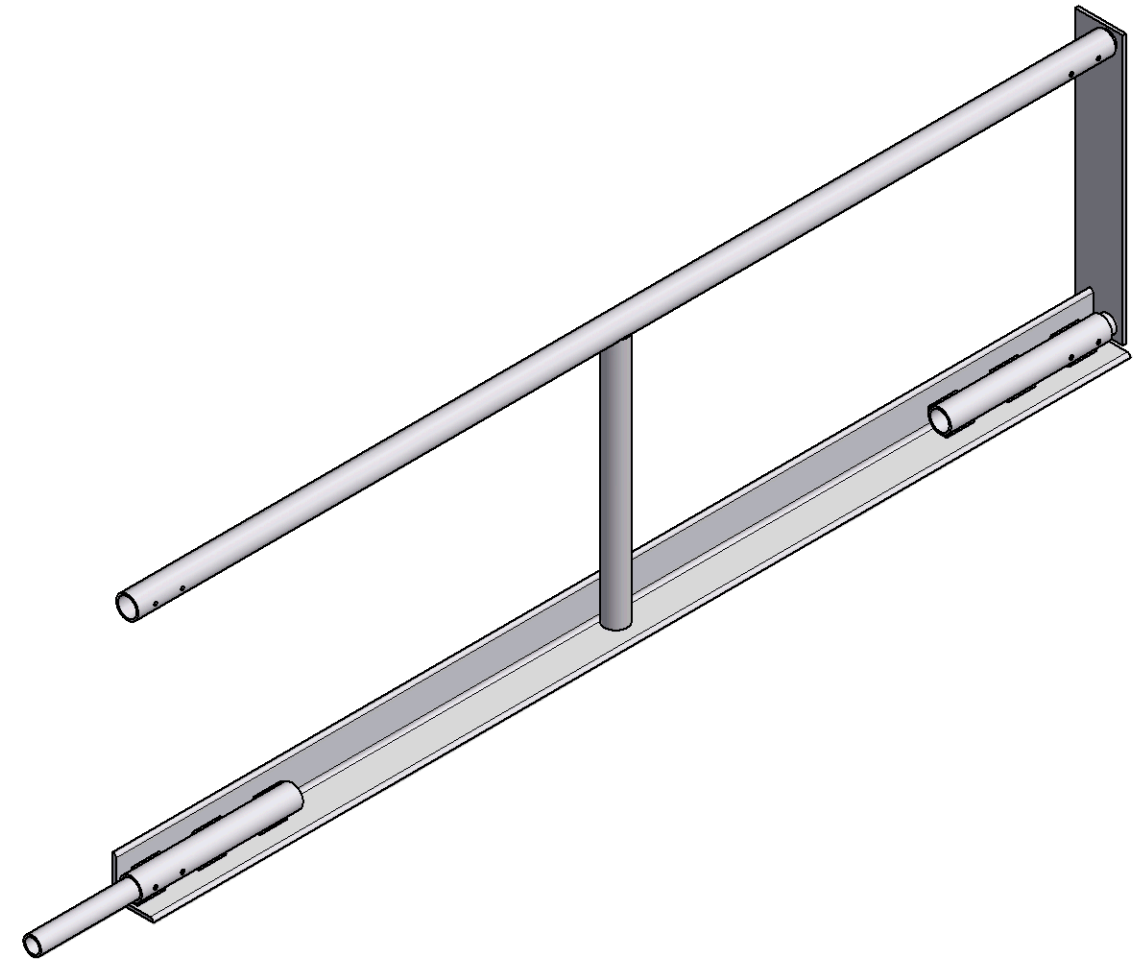
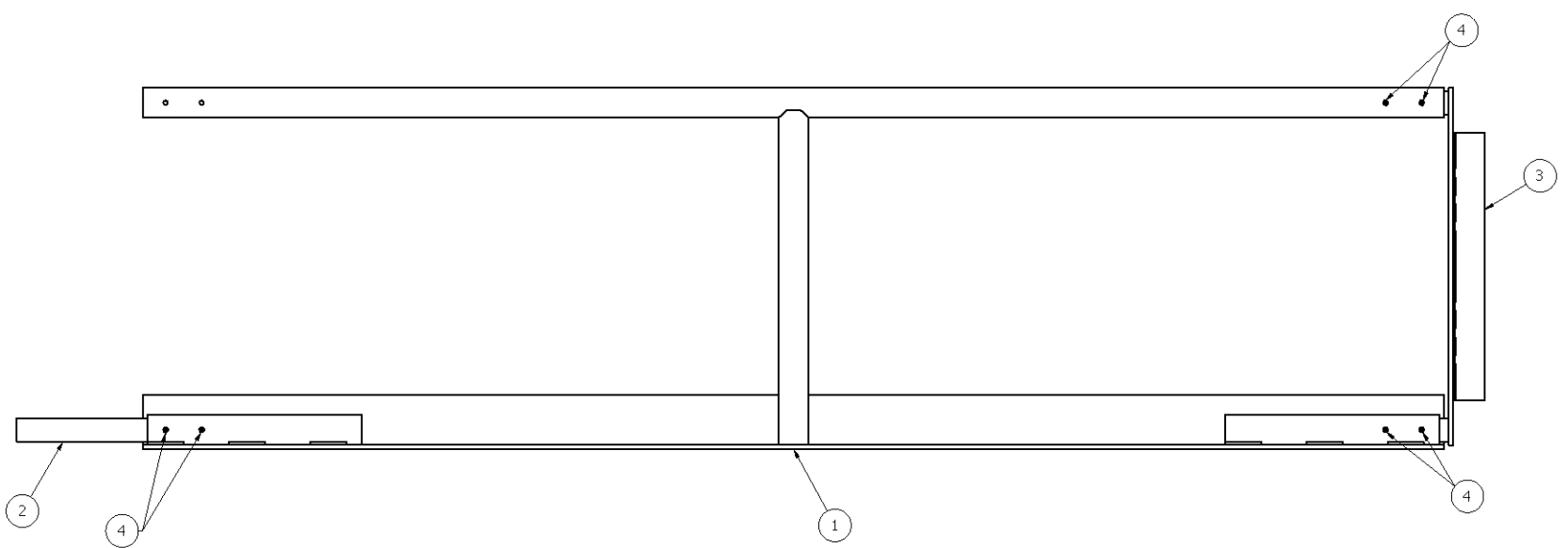
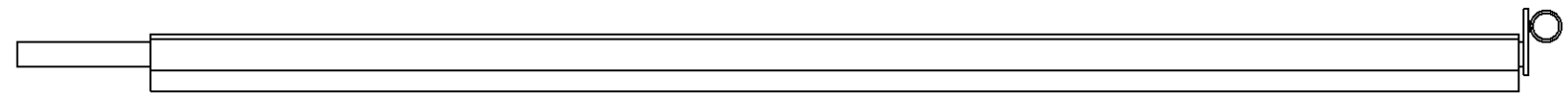

Parts List			
ITEM	QTY	PART NUMBER	DESCRIPTION
1	1	FE-00005	Field Rail
2	1	FE-00026	Connecting Pin
3	1	FE-00018	Corner Connector
4	6	HW-00010	Pop Rivet 3/16 Dia.

DRAWN dfoster	6/6/2008	FIRST 200 Bedford Street, Manchester, NH 03101 (603) 666-3906 -- FAX (603) 666-3907	
CHECKED			
UNLESS OTHERWISE SPECIFIED		TITLE	
TOLERANCES: (INCHES)		Field Rail Assy - Left	
FRAC.	+/- 1/32	SIZE	DWG NO
.00	+/- .01	D	FE-00023
.000	+/- .005	SCALE	REV
ANGULAR	+/- .25 Deg.		1

8 7 6 5 4 3 2 1

8 7 6 5 4 3 2 1

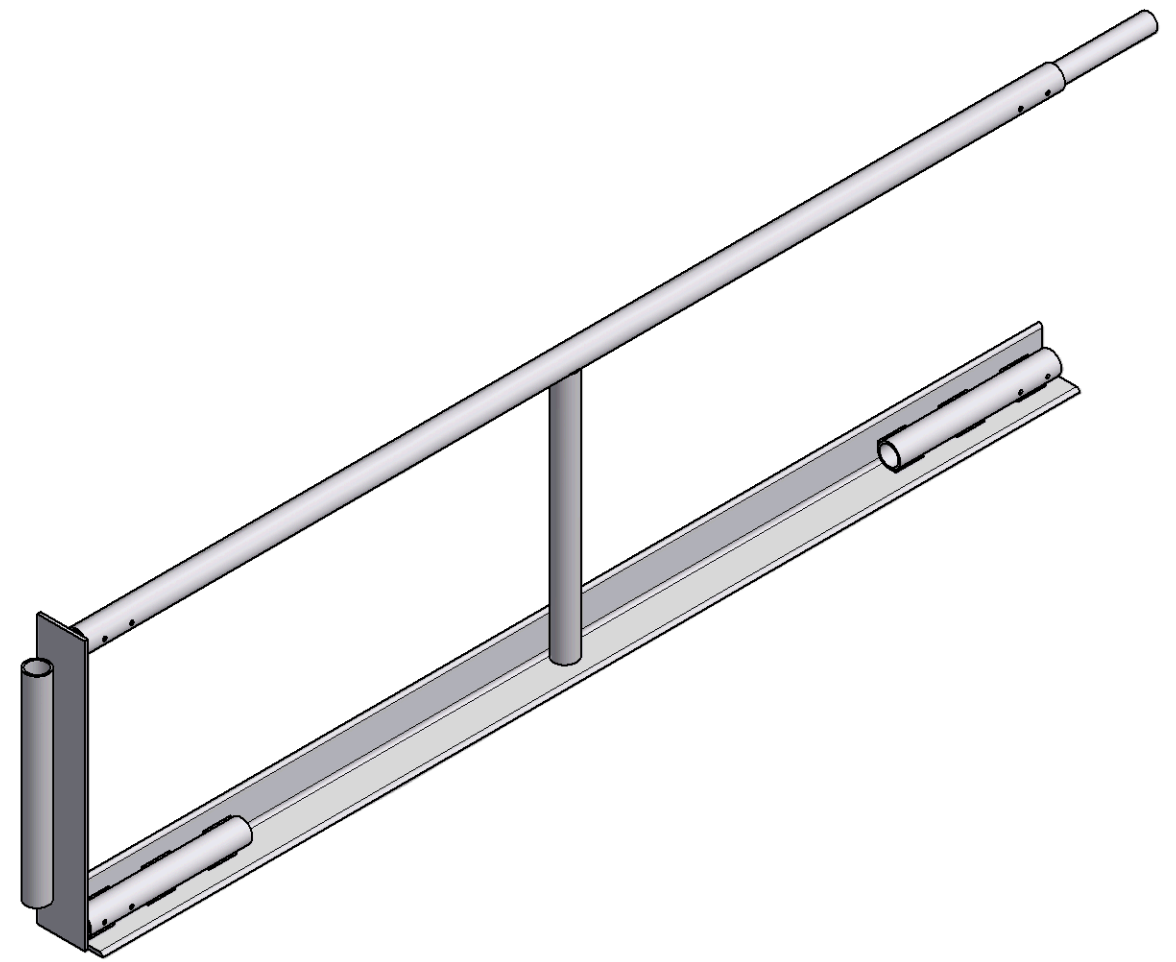
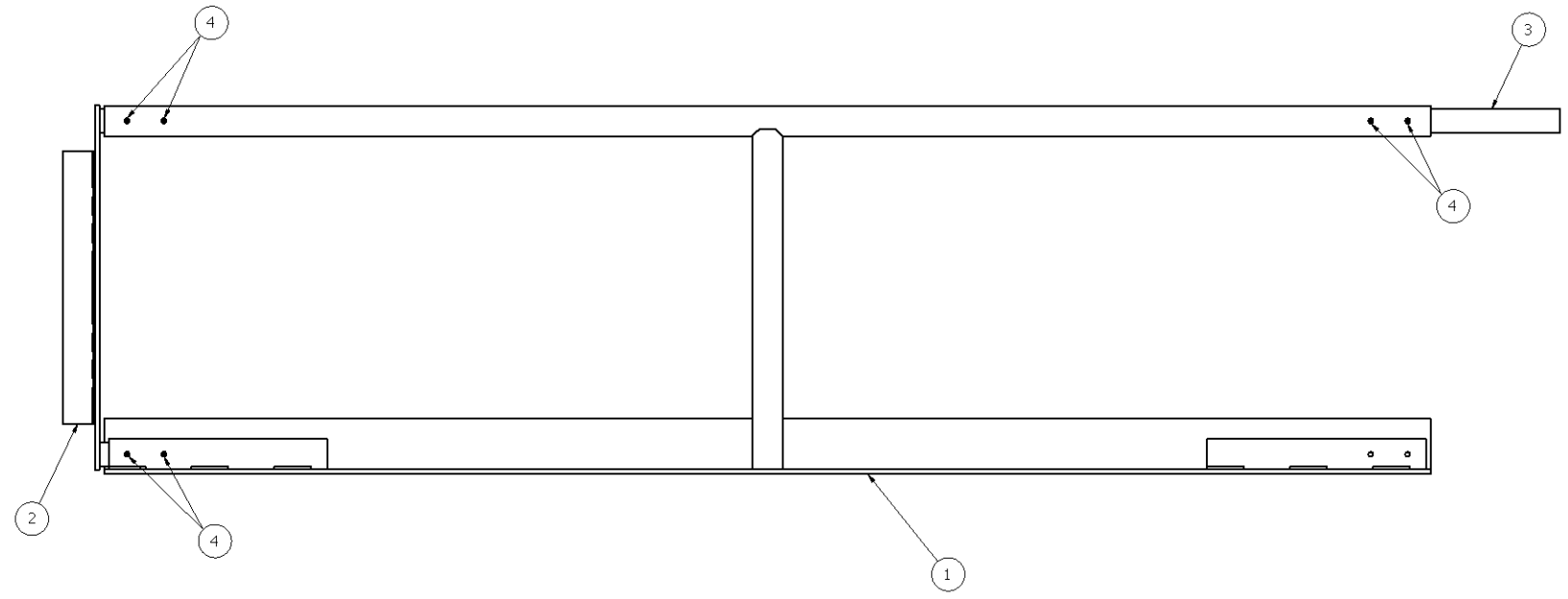

Parts List			
ITEM	QTY	PART NUMBER	DESCRIPTION
1	1	FE-00005	Field Rail
2	1	FE-00018	Corner Connector
3	1	FE-00026	Connecting Pin
4	6	HW-00010	Pop Rivet 3/16 Dia.

DRAWN dfoster CHECKED	6/6/2008	FIRST 200 Bedford Street, Manchester, NH 03101 (603) 666-3906 -- FAX (603) 666-3907	
UNLESS OTHERWISE SPECIFIED TOLERANCES: (INCHES)		TITLE Field Rail Assy - Right	
FRAC.	+/- 1/32	SIZE	DWG NO
.00	+/- .01	D	FE-00024
.000	+/- .005	SCALE	REV 1
ANGULAR	+/- .25 Deg.	SHEET 1 OF 1	

8 7 6 5 4 3 2 1

REVISION HISTORY				
ZONE	REV	DESCRIPTION	DATE	APPROVED
	1	redrawn	6/5/2008	dfoster

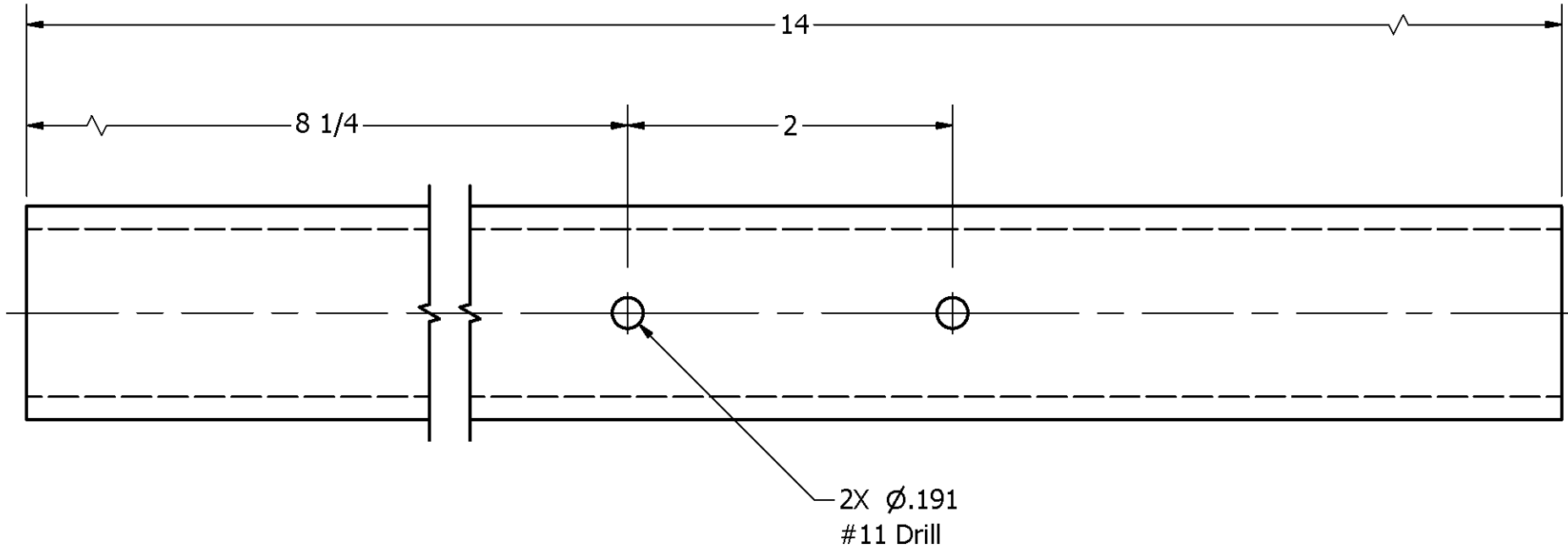
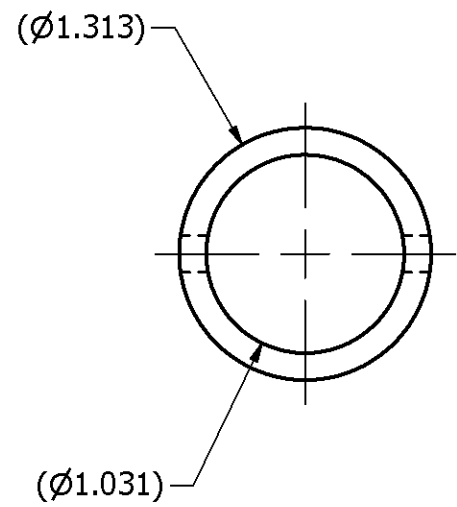

- Notes:
1. Material: 1" Schedule 40 Pipe, 6061-T6 Aluminum
 2. Remove all sharp edges.

DRAWN dfoster	6/5/2008	FIRST 200 Bedford Street, Manchester, NH 03101 (603) 666-3906 -- FAX (603) 666-3907		
CHECKED narosenberg	8/4/2008			
UNLESS OTHERWISE SPECIFIED		TITLE Connector Pin		
TOLERANCES: (INCHES)				
FRAC.	+/- 1/32			
.00	+/- .01			
.000	+/- .005	SIZE B	DWG NO FE-00026	REV 1
ANGULAR	+/- .25 Deg.	SCALE	SHEET 1 OF 1	

REVISION HISTORY				
ZONE	REV	DESCRIPTION	DATE	APPROVED
	1	redrawn	8/8/2008	dfoster

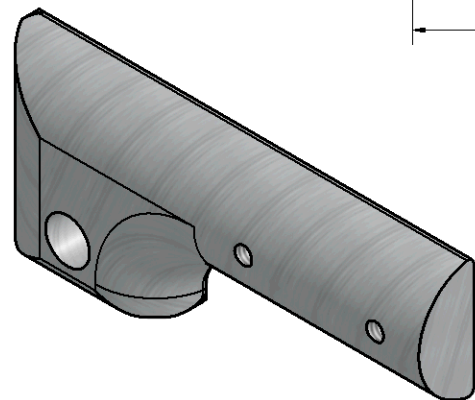
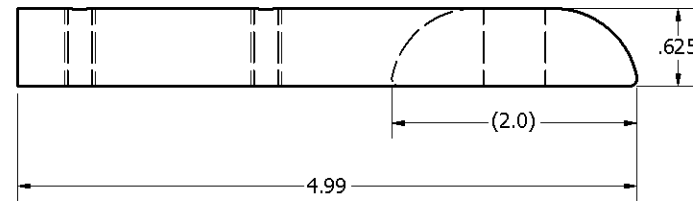
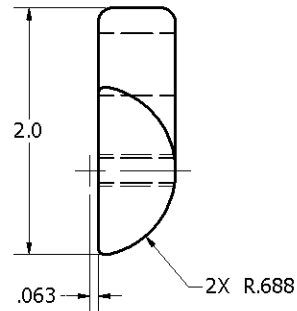
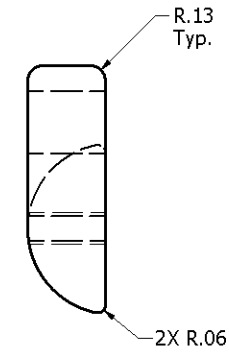
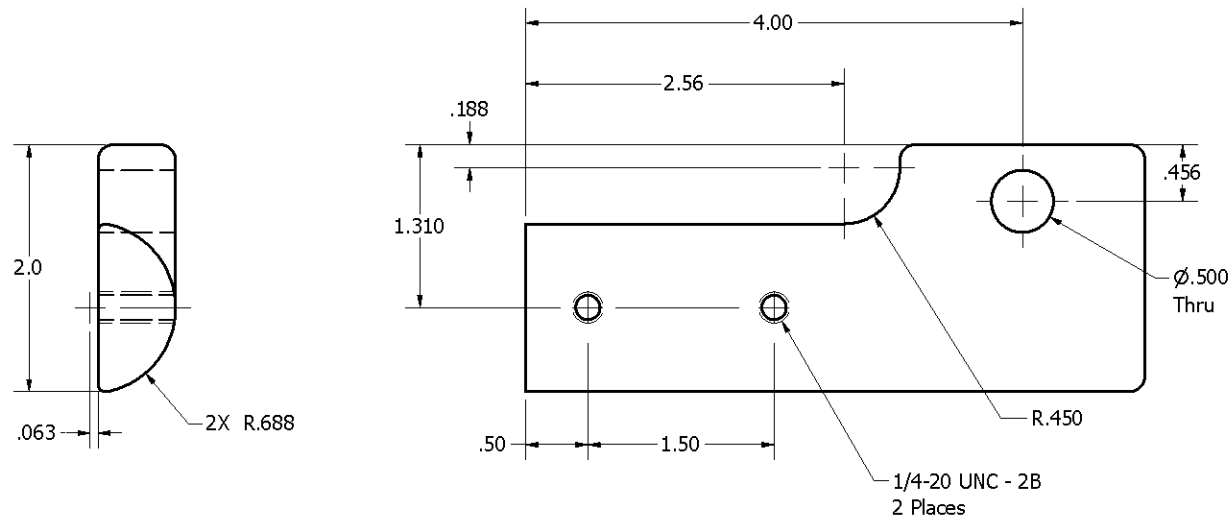
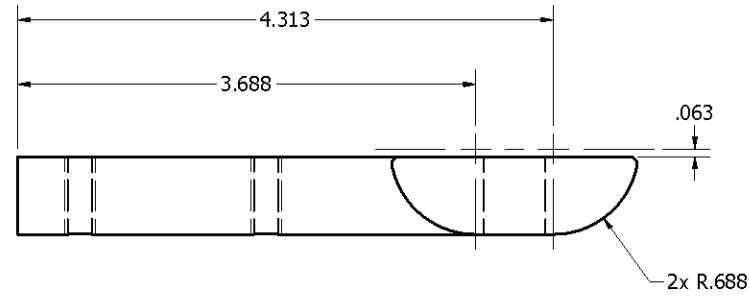

Notes:

1. Material: 6063 Aluminum
2. Remove all sharp edges

DRAWN dfoster	8/8/2008	FIRST 200 Bedford Street, Manchester, NH 03101 (603) 666-3906 -- FAX (603) 666-3907		
CHECKED narosenberg	8/8/2008			
UNLESS OTHERWISE SPECIFIED		TITLE		
TOLERANCES: (INCHES)		Hinge, Insert		
FRAC.	+/- 1/32	SIZE	DWG NO	REV
.00	+/- .01	C	FE-00027	1
.000	+/- .005	SCALE	SHEET 1 OF 1	
ANGULAR	+/- .25 Deg.			

REVISION HISTORY				
ZONE	REV	DESCRIPTION	DATE	APPROVED
	1	Redrawn	8/6/2008	dfoster

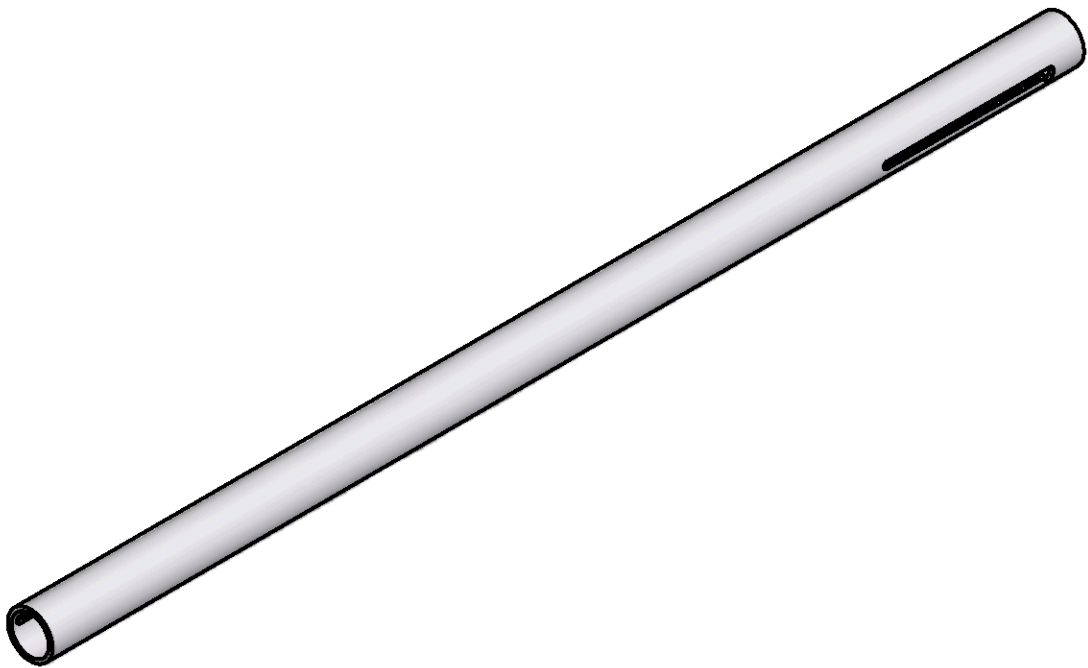
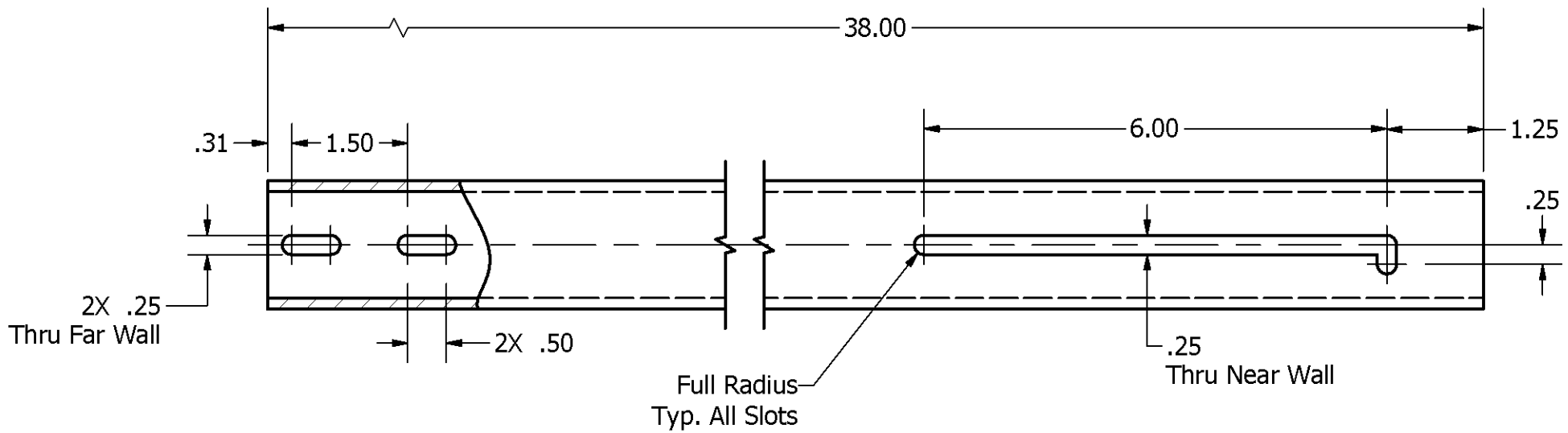
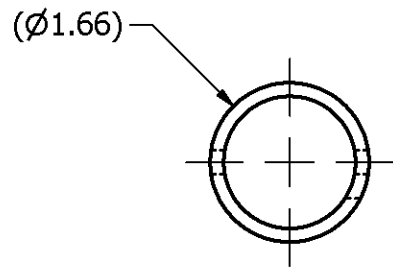

Notes:

1. Material: 1-1/4" Aluminum 6061-T6 Schedule 40 Pipe
2. Remove all sharp edges.

DRAWN dfoster	8/7/2008	FIRST 200 Bedford Street, Manchester, NH 03101 (603) 666-3906 -- FAX (603) 666-3907		
CHECKED narosenberg	8/12/2008			
UNLESS OTHERWISE SPECIFIED		TITLE Arm, Field Gate		
TOLERANCES: (INCHES)				
FRAC.	+/- 1/32			
.00	+/- .01			
.000	+/- .005	SIZE B	DWG NO FE-00028	REV 1
ANGULAR	+/- .25 Deg.	SCALE	SHEET 1 OF 1	

REVISION HISTORY				
ZONE	REV	DESCRIPTION	DATE	APPROVED
C-2, A-6, C-3	A	Relocated Item 3 (x2), Relocated Detail A	1/7/2009	dfoster

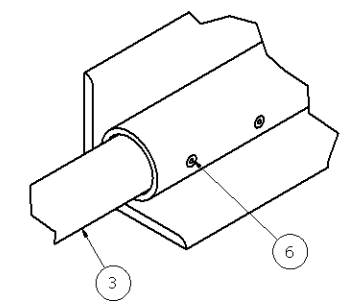
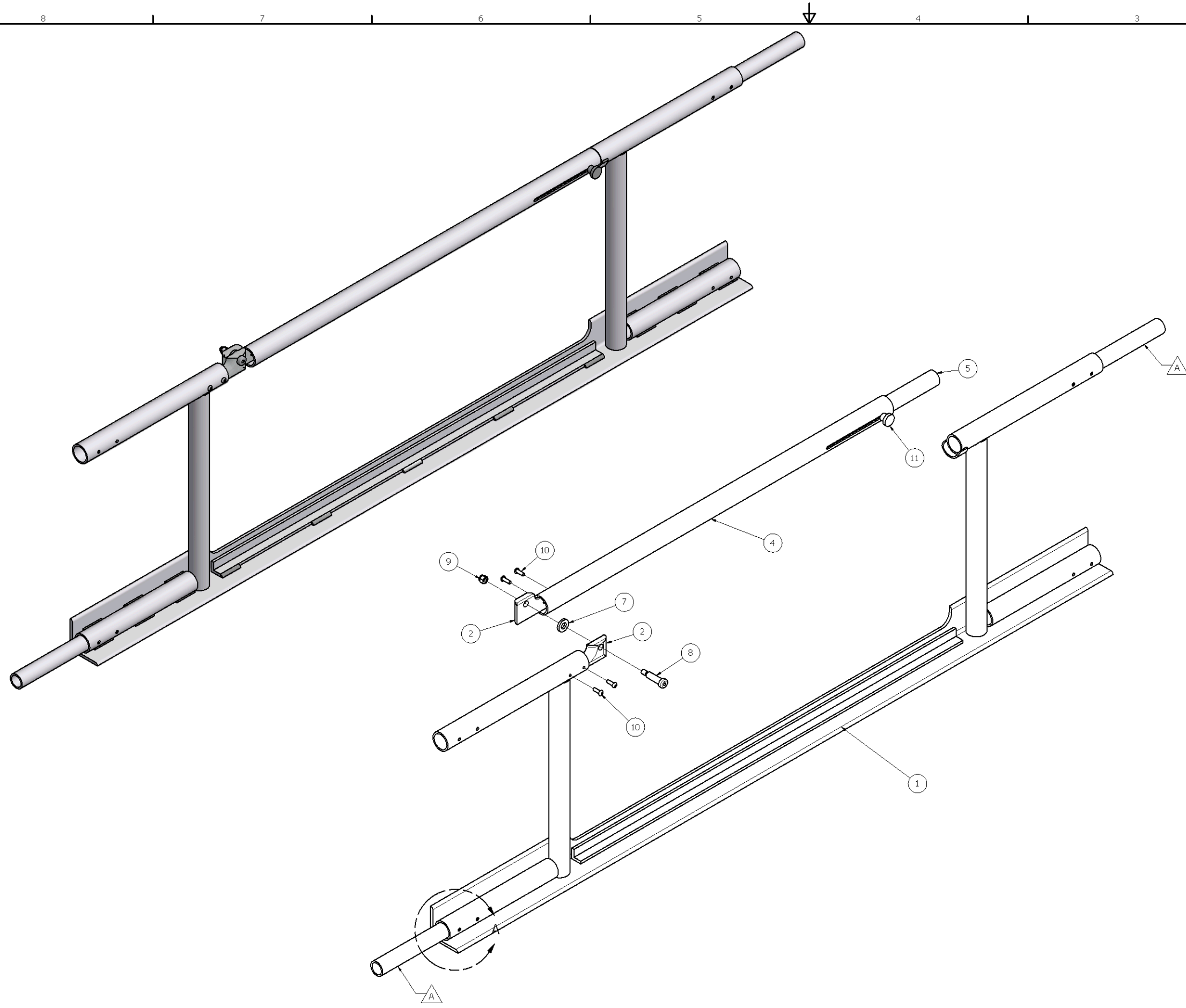

DETAIL A
SCALE 1 / 2
Typ. 2 Places

Parts List			
ITEM	QTY	PART NUMBER	DESCRIPTION
1	1	FE-00006	Field Gate, Weldment
2	2	FE-00027	Hinge Insert
3	2	FE-00026	Connecting Pin
4	1	FE-00028	Arm, Field Gate
5	1	FE-00031	Slide, Gate
6	4	HW-00010	Pop Rivet 3/16 Dia.
7	1	HW-00035	Washer, Flat 1/2"
8	1	HW-00036	Socket Head Shoulder Screw, 1/2" x 1.5"
9	1	HW-00026	Nut, Nylock 3/8-16 Zinc Plate
10	4	HW-00037	Socket Button Head Cap Screw, 1/4-20 x .75"
11	1	PP-00012	Knob, Round Knurled with threaded Stud McMaster-Carr 6091K61

DRAWN dfoster		1/2/2009	FIRST 200 Bedford Street, Manchester, NH 03101 (603) 666-3906 -- FAX (603) 666-3907	
CHECKED				
UNLESS OTHERWISE SPECIFIED				
TOLERANCES: (INCHES)				
FRAC.	+/- 1/32		TITLE Field Gate, Assembly	
.00	+/- .01		SIZE D	DWG NO FE-00029
.000	+/- .005		SCALE	REV A
ANGULAR	+/- .25 Deg.		SHEET 1 OF 1	

4

3

2

1

B

B

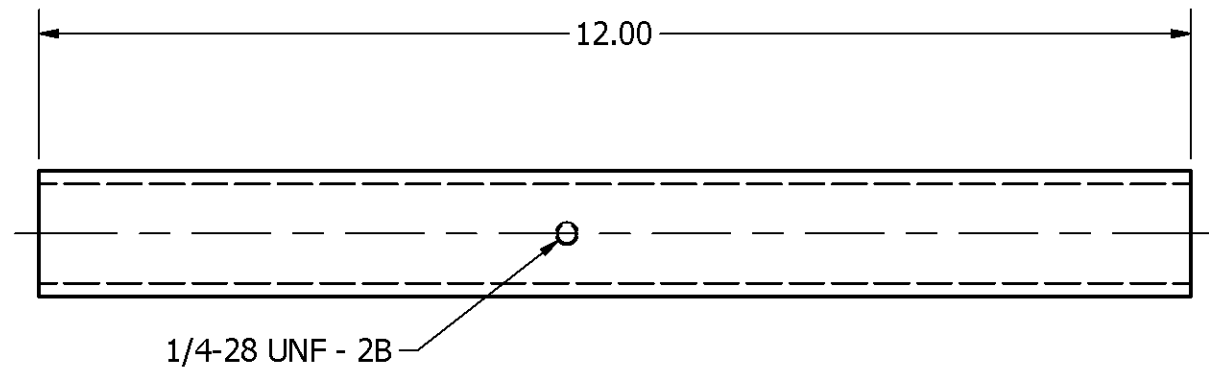
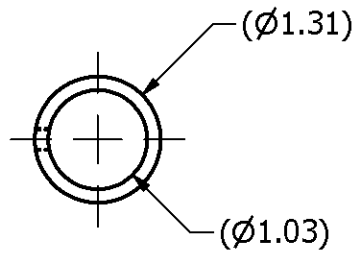

Notes:

- 1. Material: 1" Schedule 40 Aluminum 6061-T6.
- 2. Remove all sharp edges.

DRAWN dfoster		1/2/2009		FIRST 200 Bedford Street, Manchester, NH 03101 (603) 666-3906 -- FAX (603) 666-3907	
CHECKED					
UNLESS OTHERWISE SPECIFIED				TITLE Slide, Gate	
TOLERANCES: (INCHES)					
FRAC.	+/-	1/32			
.00	+/-	.01			
.000	+/-	.005		SIZE B	DWG NO FE-00031
ANGULAR	+/-	.25 Deg.		SCALE	SHEET 1 OF 1

4

3

2

1

A

A

4

MODEL NAME
FE-00050

TITLE

Outrigger

1

2

3

4

D

D

C

C

B

B

A

A

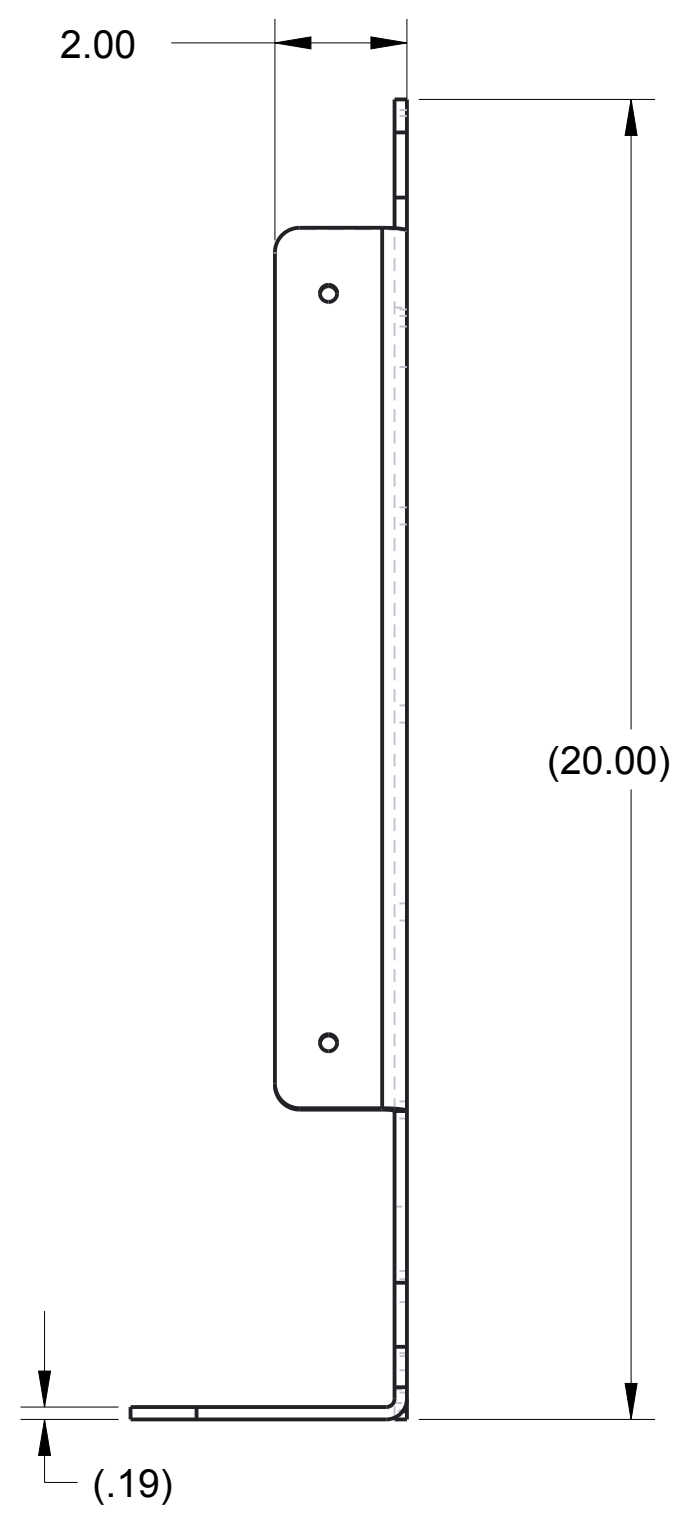
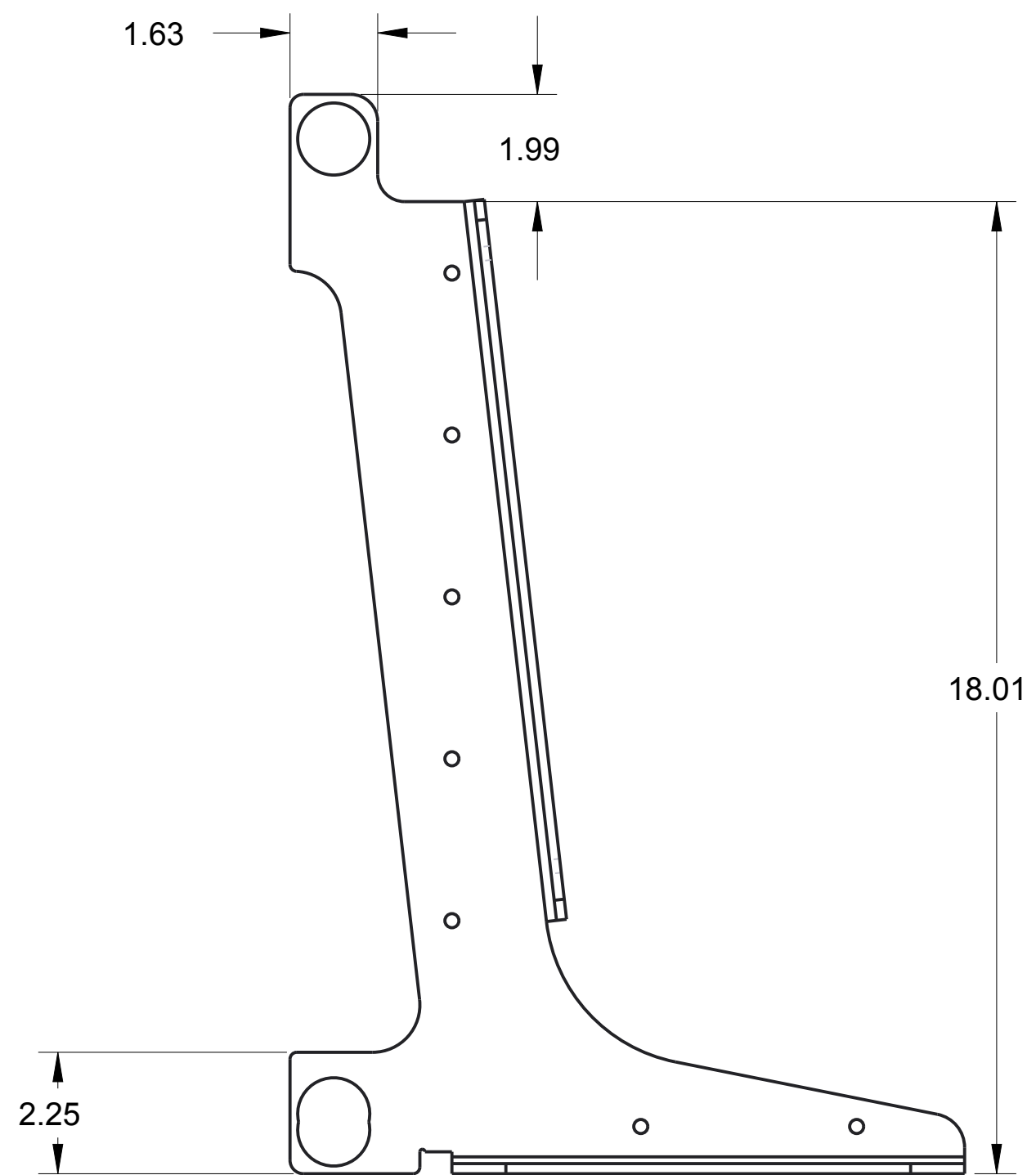
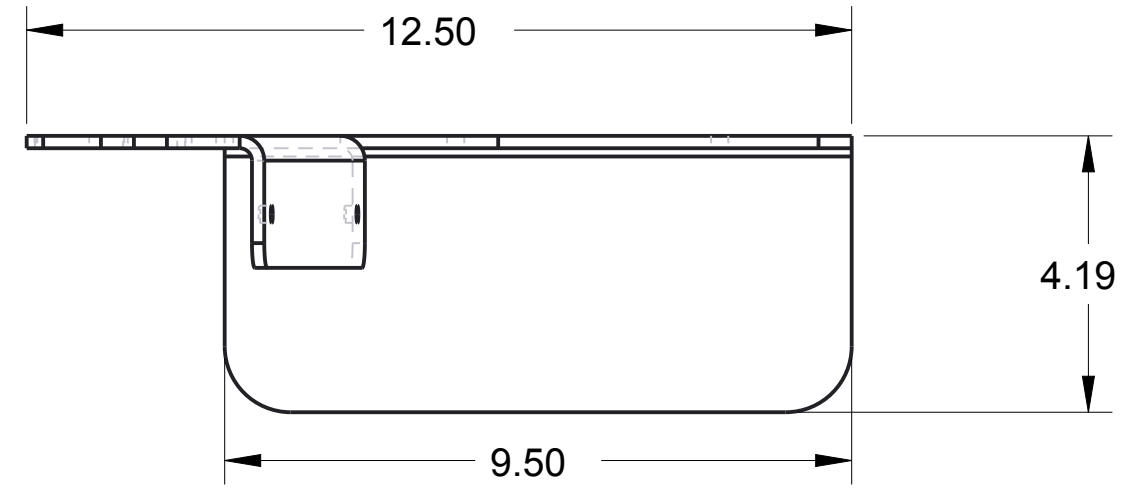

SCALE 1:4

Note:

Material: 5052 Aluminum Sheet, 3/16" Thick

This drawing represents overall dimensions for AndyMark AM-2810. Please see the AndyMark website for more details regarding part dimensions.

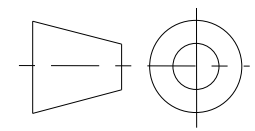

DRAWN BY	DATE
CHECKED BY	DATE
APPROVED BY	DATE
SCALE 11:32	SHEET 1 OF 1

UNLESS OTHERWISE SPECIFIED ALL DIMENSIONS ARE IN INCHES.
TOLERANCES ARE:
X.X +/- 0.1
X.XX +/- 0.01
X.XXX +/- 0.001
ANG +/- 1

DO NOT SCALE

TITLE Outrigger	
PROJECT	MODEL NAME FE-00050
ISSUE	

1

2

3

4

MODEL NAME
FE-00047

TITLE
Gate Plastic Assembly

D

D

C

C

B

B

A

A

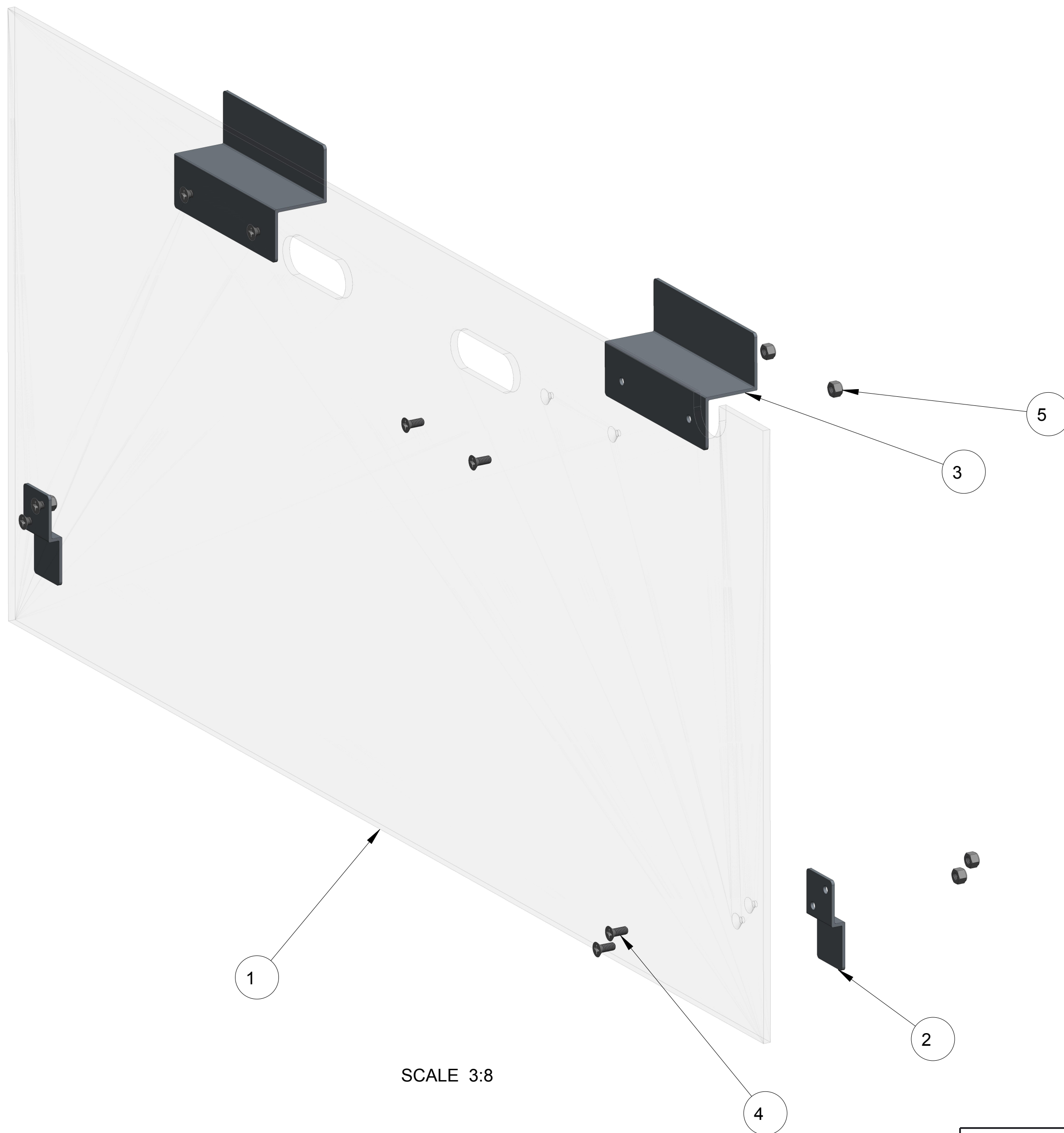

SCALE 3:8

ITEM NO	PART NUMBER	QTY	DESCRIPTION	NOTES
1	FE-00044	1	Field Plastic, G	
2	FE-00045	2	Lower Z-Bracket	
3	FE-00046	2	Upper Z-Bracket	
4	HW-00047-01	8	5/8 Phillips Machine Screw 1/4-20	
5	HW-00047-02	8	1/4-20 Nyloc Hex Nut	

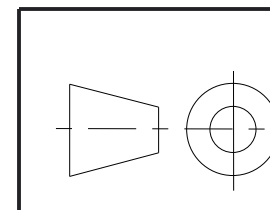

DRAWN BY	DATE
CHECKED BY	DATE
APPROVED BY	DATE

THIS DOCUMENT IS SUPPLIED IN CONFIDENCE. NO REPRODUCTION OF THIS DOCUMENT IN PART OR IN WHOLE OR THEREON OF THE ITEMS SHOWN MAY BE MADE WITHOUT THE COPYRIGHT OWNERS WRITTEN PERMISSION

SCALE 7:64 SHEET 1 OF 1

UNLESS OTHERWISE SPECIFIED ALL DIMENSIONS ARE IN INCHES.
TOLERANCES ARE:
X.X +/- 0.1
X.XXX +/- 0.01
X.XXXX +/- 0.001
ANG +/- 1

TITLE
Gate Plastic Assembly

PROJECT	MODEL NAME FE-00047	ISSUE
---------	------------------------	-------

DO NOT SCALE

1

2

3

4

REV	DESCRIPTION	INITIALS	DATE
A	Added counter sincks, hand holes and a notch	MLC	9/23/14

D

D

C

C

B

B

A

A

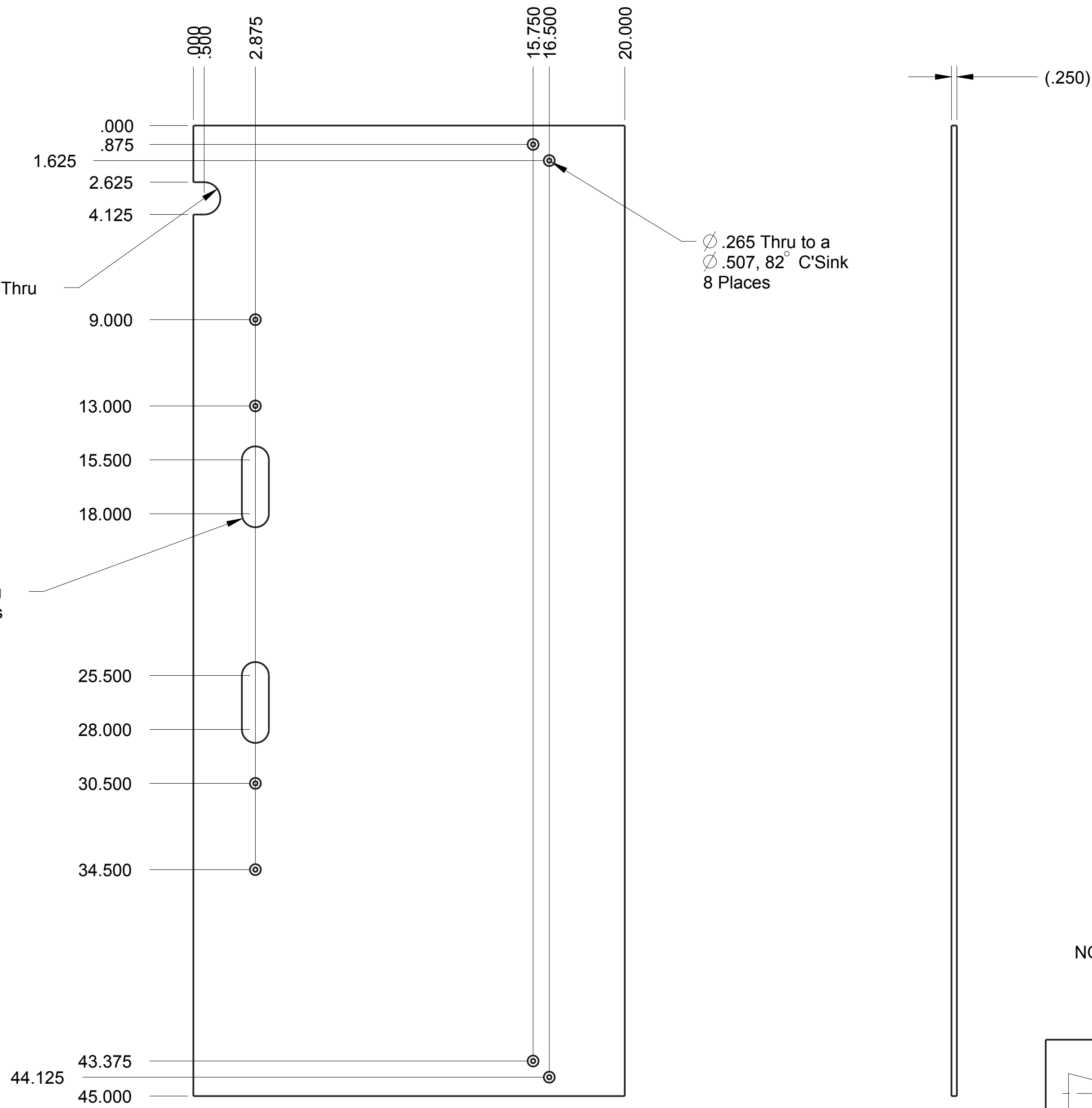

- NOTES:
 1. Material: 1/4" Clear Polycarbonate
 2. Remove all burrs and sharp edges

		DRAWN BY	DATE
		CHECKED BY	DATE
		APPROVED BY	DATE
<small>THIS DOCUMENT IS SUPPLIED IN CONFIDENCE. NO REPRODUCTION OF THIS DOCUMENT IN PART OR IN WHOLE OR THEREON OF THE ITEMS SHOWN MAY BE MADE WITHOUT THE COPYRIGHT OWNERS WRITTEN PERMISSION</small>		SCALE 1:4	SHEET 1 OF 1
TITLE Field Plastic "G"		PROJECT	MODEL NAME FE-00044
UNLESS OTHERWISE SPECIFIED ALL DIMENSIONS ARE IN INCHES. TOLERANCES ARE: .XX +/- 0.1 .XXX +/- 0.01 X.XXX +/- 0.001 ANG +/- 1		ISSUE	
DO NOT SCALE			

D

D

C

C

B

B

A

A

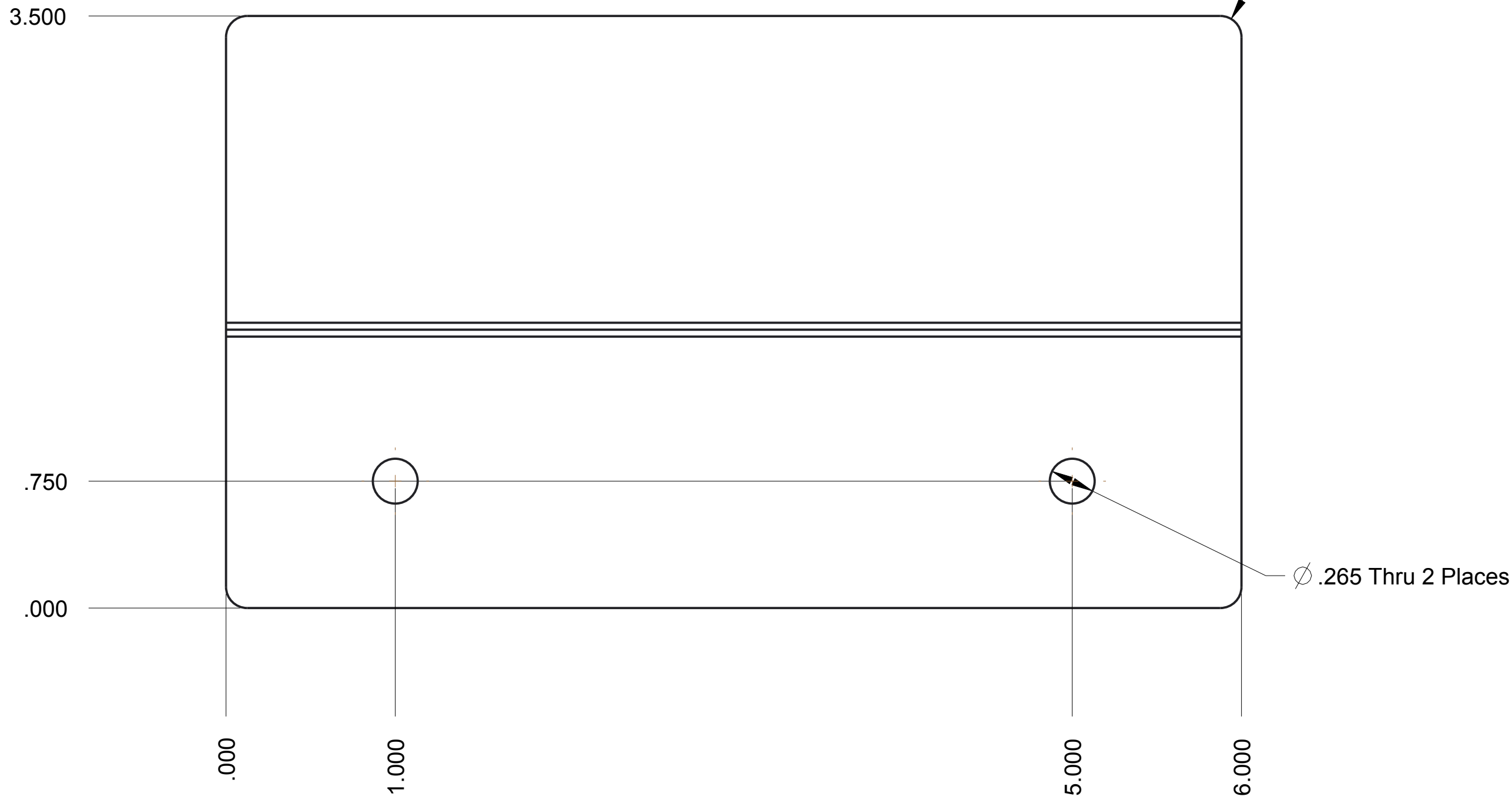

- Notes:
 1.) 12 Gauge 5052 Aluminum
 2.) Remove all burs and sharp edges

		DRAWN BY	DATE
		CHECKED BY	DATE
<small>UNLESS OTHERWISE SPECIFIED ALL DIMENSIONS ARE IN INCHES. TOLERANCES ARE: .XX +/- 0.1 .XXX +/- 0.01 .XXXX +/- 0.001 ANG +/- .1</small>	THIS DOCUMENT IS SUPPLIED IN CONFIDENCE. NO REPRODUCTION OF THIS DOCUMENT IN PART OR IN WHOLE OR THEREON OF THE ITEMS SHOWN MAY BE MADE WITHOUT THE COPYRIGHT OWNERS WRITTEN PERMISSION	APPROVED BY	DATE
		SCALE 3:2	SHEET 1 OF 1
TITLE Upper Z-Bracket, Gate Plastic			
PROJECT		MODEL NAME FE-00046	ISSUE
DO NOT SCALE			

1

2

3

4

D

D

C

C

B

B

A

A

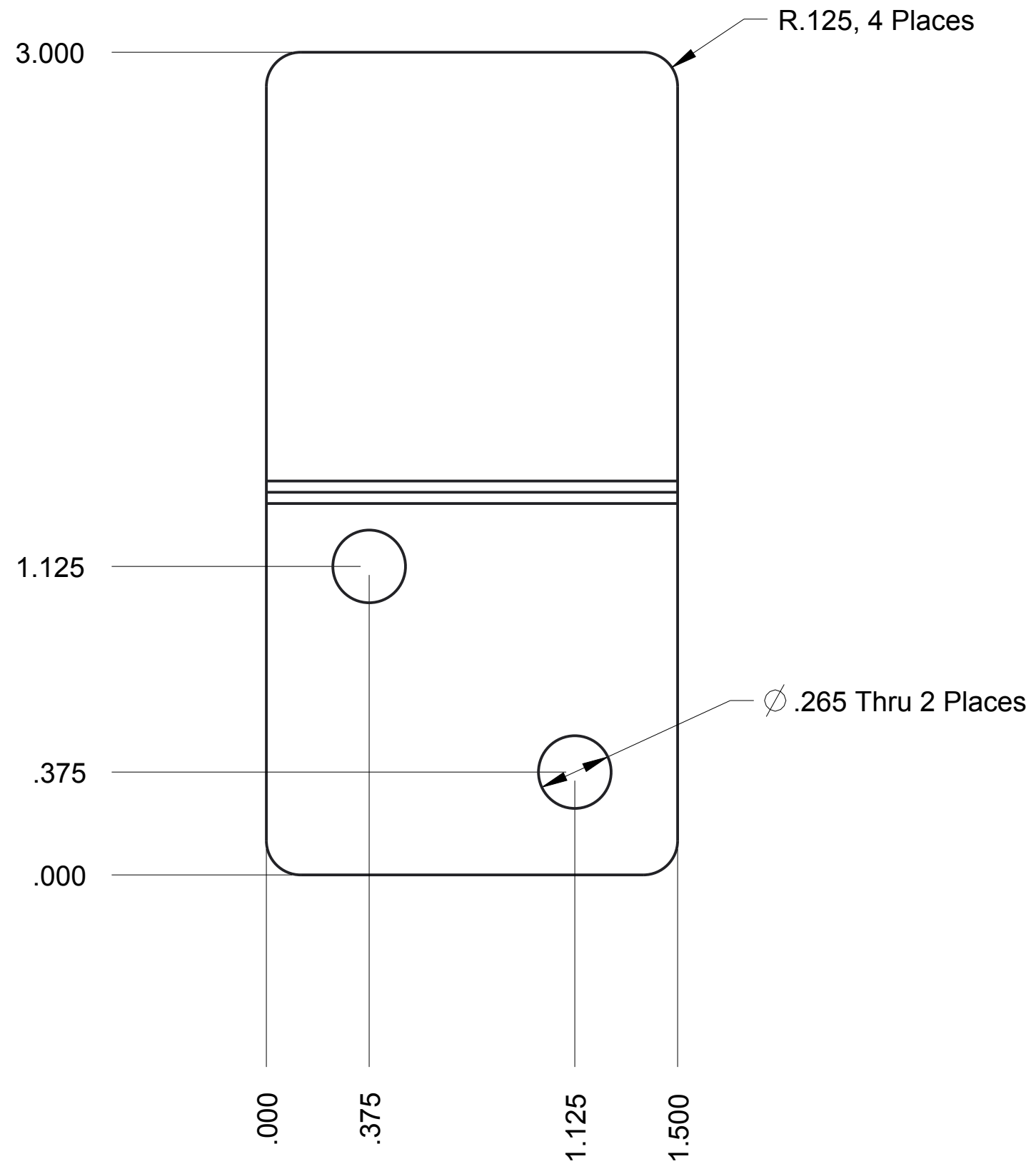

Minimal Radius, TYP

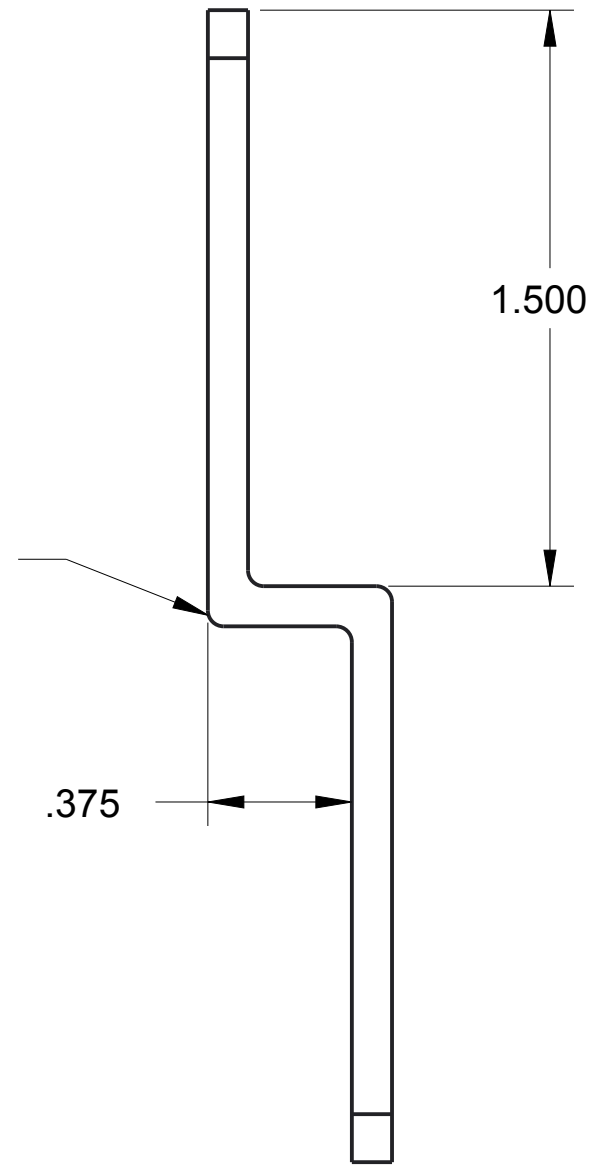

Notes:

- 1.) 12 Gauge 5052 Aluminum
- 2.) Remove all burs and sharp edges

		DRAWN BY	DATE
		CHECKED BY	DATE
<small>UNLESS OTHERWISE SPECIFIED ALL DIMENSIONS ARE IN INCHES. TOLERANCES ARE: X.X +/- 0.1 X.XX +/- 0.01 X.XXX +/- 0.001 ANG +/- 1</small>	<small>THIS DOCUMENT IS SUPPLIED IN CONFIDENCE. NO REPRODUCTION OF THIS DOCUMENT IN PART OR IN WHOLE OR THEREON OF THE ITEMS SHOWN MAY BE MADE WITHOUT THE COPYRIGHT OWNERS WRITTEN PERMISSION</small>	APPROVED BY	DATE
		SCALE 2:1 SHEET 1 OF 1	
TITLE Lower Z-Bracket, Gate Plastic			
PROJECT		MODEL NAME FE-00045	ISSUE
DO NOT SCALE			

1

2

3

4