

Section
8



THE ROBOT

TABLE OF CONTENTS

8 THE ROBOT	2
8.1 OVERVIEW.....	2
8.1.1 What is a FIRST Robot?.....	2
8.1.2 Getting Started.....	2
8.1.3 Related Documents & Resources.....	3
8.1.4 Conventions.....	3
8.2 DEFINITIONS	3
8.3 ROBOT RULES	6
8.3.1 General Design & Safety Rules	7
8.3.2 Robot Physical Rules.....	8
8.3.3 Fabrication Schedule	10
8.3.4 Robot Material Utilization Rules.....	12
8.3.5 Electrical System Rules	21
8.3.6 Custom Circuit Rules	22
8.3.7 Control System Rules	23
8.3.8 Operator Interface Rules.....	24
8.3.9 Wiring Rules	25
8.3.10 Pneumatic System Rules.....	26
8.3.11 Non-Functional Decoration Rules	28
8.3.12 Robot Inspection Rules.....	28

8 THE ROBOT

8.1 OVERVIEW

This section of the 2007 *FIRST* Robotics Competition Manual provides:

- NEW Rules applicable to the design and construction of the 2007 Robot.
- Descriptions of NEW mechanical and electrical systems that are based on parts provided in the 2007 Kit Of Parts (KOP).

Compliance with all Rules is mandatory.

Robots will be inspected at each *FIRST* event to verify rules compliance before being allowed to compete.

8.1.1 What is a FIRST Robot?

A *FIRST* robot is a remotely operated vehicle designed and built by a *FIRST* Robotic Competition team to perform specific tasks when competing in the 2007 competition "Rack 'n' Roll".

8.1.2 Getting Started

Please be sure to thoroughly read and understand Sections 4, 6, 7, 8, and 9 of this manual before designing your robot. In particular, pay attention to *Section 8.3.1. General Design & Safety Rules* and *Section 8.3 Robot Rules* before proceeding. The following are just a few important points offered to help teams in getting started:

- 1) Evaluate the Game's physical challenges and identify those that the robot will have to overcome.
 - Will it have to climb, pick and place items, push / pull objects or robots, possess a low profile, extend its height, lift items, hang, etc.?
 - What are the game's implications regarding the robot's center of gravity?
 - Are unique field surface characteristics important when determining robot driving mechanism design?
 - Are there any particular offensive / defensive capabilities important to the robot?
- 2) Inspect all items provided in the Kit Of Parts (see Section 10) and review their basic features. Note that suppliers' data sheets are referenced in the Kit Of Parts tables for many of the components in the Kit.
- 3) We recommend that you carefully read the documents listed in Section 8.1.3 Related Documents & Resources.
- 4) Look over the specifications and technical notes provided for the various Kit Of Parts components.
- 5) Note all Safety Rules relating to the robot's design. They include:
 - The locations and ratings of circuit breakers where indicated in the wiring diagrams
 - Wire size
 - Stored energy guidelines
 - Attention to sharp corners and edges

- Shields for moving parts and pinch points

8.1.3 Related Documents & Resources

In addition to this chapter, other sections in this manual and other documents should be reviewed before proceeding with the robot design process. Note that all referenced documents are available on-line at http://www.usfirst.org/robotics/doc_updt.htm

- Section 6: The Arena, Section 7: The Game and Section 9: The Tournament
- Section 4.5.1.1: Crate Shipping Deadlines as listed in Section 4: Robot Transportation
- *FIRST* Guidelines, Tips, and Good Practices
- Innovation First, Inc. instruction manuals for the *Robot Controller*, *Spike relay modules*, and *Victor 884 speed controllers* as provided by their manufacturer
- *FIRST* 2007 Chassis Kit Manual – Information to assemble chassis kit available at: <http://www.ifirobotics.com/kitbot.shtml>.
- *FIRST* 2007 Software Quick Start Guide – A guide to software tools available for robot and vision system programming.
- 2007 CMUCam2 Engineering Workbook – A guide to vision system programming using EasyC software applications.
- *FIRST* 2007 Pneumatics Manual - Valuable information about the pneumatic components and ordering processes are included.
- *FIRST* 2007 Sensors Manual – Helpful information regarding the application, assembly, and programming of the sensors included in the 2007 Kit Of Parts.
- 2007 Robot Power Distribution Diagram

8.1.4 Conventions

Specific methods are used throughout this section to highlight warnings, cautions, key words or phrases to alert the reader to important information designed to help teams in constructing a robot complying with the rules in a safe and workmanlike manner.

Warnings, cautions, and notes appear in bordered boxes. Key words that have a particular meaning within the context of the 2007 *FIRST* Robotics Competition are defined in Sections 6, 7.2 and 8.2, and indicated in ALL CAPITAL letters throughout this text. References to other sections of the manual appear in ***bold italics***. References to specific rules within the manual are indicated with a bracketed reference to the rule (e.g. “Rule <S01>”). Operating keys, controls, buttons appear in bold capital letters (i.e. **OFF/ON** switch or **RESET** button).

8.2 DEFINITIONS

COMPONENT – A **ROBOT** part in its most basic configuration, which can not be disassembled without damaging or destroying the part, or altering its fundamental function.

- Example 1: raw aluminum stock, pieces of steel, wood, etc., cut to the final dimensions in which they will be used on the **ROBOT**, would all be considered components. Bolting pieces of extruded aluminum together as a **ROBOT** frame would constitute a **MECHANISM**, and the collection of pieces would not be considered a **COMPONENT**.
- Example 2: a COTS (See immediately below) circuit board is used to interface to a sensor on the **ROBOT**, and it includes the circuit board and several electrical elements soldered to the board. The board is considered a **COMPONENT**, as this is the basic form in which

it was purchased from the vendor, and removing any of the electrical elements would destroy the functionality of the board.

COTS – A “Commercial, Off-The-Shelf” COMPONENT or MECHANISM, in it’s unaltered, unmodified state. A COTS item must be a standard (i.e. not custom order) part commonly available from the VENDOR, available from a non-team source, and available to all teams for purchase.

- Example 1: a team orders two robot grippers from RoboHands Corp. and receives both items. They put one in their store room and plan to use it later. Into the other, they drill “lightening holes” to reduce weight. The first gripper is still classified as a COTS item, but the second gripper is now a “custom part” as it has been modified.
- Example 2: a team obtains openly available blueprints of a drive component commonly available from Wheels-R-Us Inc. and has local machine shop “We-Make-It, Inc.” manufacture a copy of the part for them. The produced part is NOT a COTS item, because it is not commonly carried as part of the standard stock of We-Make-It, Inc.

FABRICATED ITEM – Any COMPONENT or MECHANISM that has been altered, built, cast, constructed, concocted, created, cut, heat treated, machined, manufactured, modified, painted, produced, surface coated, or conjured into the final form in which it will be used on the ROBOT.

- Example 1: A piece of extruded aluminum has been ordered by the team, and arrives in a 20-foot length. To make it fit in their storage room, the team cuts it into two ten-foot lengths. These would not be considered FABRICATED ITEMS, as they have not been cut to the final length in which they will be used on the ROBOT.
- Example 2: A team designs an arm mechanism that uses gears with a 1/2-inch face width. They order a 12-inch length of gear stock and cut it into precise 1/2 inch slices. They do not bore out the mounting bores in the center of the gears. The slices are now considered FABRICATED ITEMS, as they have been cut to final size, even though all the machining operations (the center bore) may not yet be completed.

FIX-IT-WINDOWS – Two 5-hour work periods following the deadline for shipping the ROBOT, or following the close of a regional competition, in which ALL teams may manufacture parts in preparation for future competitions. During the FIX-IT WINDOWS, software for either the ROBOT or Operator Interface may be developed without restriction. The FIX-IT WINDOWS are limited to single continuous time periods with a maximum duration of 5 hours each. Part or all of the team may participate in the work conducted during this period. The FIX-IT WINDOWS can not be subdivided into multiple work sessions of lesser duration.

FLAG – A colored (red or blue) bicycle flag used to display ALLIANCE assignments during a match. The flag itself is made of a triangular piece of colored plastic or fabric, measuring approximately 9 inches tall by 11 inches long. The flag is mounted at the end of a 1/4 inch diameter fiberglass flagpole, approximately 36 inches long.

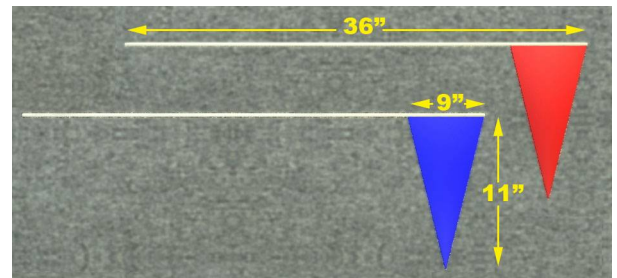

MECHANISM – A COTS or custom assembly of COMPONENTS that provide specific functionality on the ROBOT. A MECHANISM can be disassembled (and then reassembled) into individual COMPONENTS without damage to the parts.

OPERATOR CONSOLE – the Innovation First-provided Operator Interface unit and any associated equipment, control interfaces, display systems, structure, decorations, etc. used by the DRIVERS to operate the ROBOT.

PLAYING CONFIGURATION - The physical configuration and orientation of the ROBOT while playing the game (i.e. after the match has started, and the ROBOT has deployed mechanisms, moved away from the starting location, and/or interacted with the field, GAME PIECES, or other ROBOTS). This configuration is dynamic, and may change multiple times during the course of a single match.

REPLACEMENT PARTS – A COMPONENT or MECHANISM constructed as a functional duplicate of an existing part of the ROBOT, for the purpose of replacing a broken or defective part. REPLACEMENT PARTS may be either COTS items or FABRICATED ITEMS. They must be functionally identical to the original part but can be modified to provide more robust performance of the function.

- Example 1: A lever arm made of lexan on your ROBOT breaks. You manufacture a REPLACEMENT PART made of aluminum plate, using the design drawings of the original. As the new part provides the same function as the broken part, the new part is a valid REPLACEMENT PART.
- Example 2: A sensor on the ROBOT is connected to the control system with 24-gauge single-strand wire, and runs across a hinged joint. The flexing of the wire causes it to break, and you want to replace it with 18-gauge multi-strand wire. If the new wire follows the same path as the original and connects only the same devices, then it is a valid REPLACEMENT PART (i.e. it has added robustness without changing function). But if the wire is then used to connect an additional sensor to the same circuit, it is providing a functionally different capability, and is no longer a “replacement.”

SPARE PARTS – A COMPONENT or MECHANISM constructed as an identical duplicate of an existing part of the ROBOT, for the purpose of replacing a broken or defective part. SPARE PARTS may be either COTS items or FABRICATED ITEMS, but they must be physically and functionally identical to the original part.

STARTING CONFIGURATION – The physical configuration and orientation of the ROBOT when the match is started. This is the state of the ROBOT immediately before being enabled by the Arena Controller, before the ROBOT takes any actions, deploys any mechanisms, or moves away from the starting location. This configuration is static, and does not change during a single match (although it may change from match to match).

STANDARD BUMPERS – Bumper assemblies designed to attach to the exterior of the ROBOT within the BUMPER ZONE, and constructed as specified in Rule <R37>. STANDARD BUMPERS may weigh up to 15 pounds, and are excluded from the weight and volume calculations specified in Rule <R07>.

UPGRADE PARTS - A COMPONENT or MECHANISM intended to provide additional functionality not currently available on the ROBOT. UPGRADE PARTS may be COTS items or custom FABRICATED ITEMS, and may either add to or replace existing functionality.

- Example 1: A ROBOT is designed with a four-wheel drive system. The system works well on flat floors, but high-centers when trying to drive up steps. The team adds two more wheels on the centerline of the ROBOT to prevent this problem, and the wheels are identical to those already on the ROBOT. The new wheels would be considered UPGRADE PARTS even though they are the same as the ones already in place, as they alter the functionality of the ROBOT and provide new capability.

VENDOR – A legitimate business source for COTS items that, as a minimum, satisfies the following criteria:

- The VENDOR must have a Federal Tax Identification number. The Federal Tax Identification number establishes the VENDOR as a legal business entity with the IRS, and validates their status as a legitimate business. In cases where the VENDOR is outside of

the United States, they must possess an equivalent form of registration or license with the government of their home nation that establishes and validates their status as a legitimate business licensed to operate within that country.

- The VENDOR must be normally able to ship any general (i.e., non-*FIRST* unique) product within five business days of receiving a valid purchase request. It is recognized that certain unusual circumstances (such as 1,000 *FIRST* teams all ordering the same part at once from the same VENDOR) may cause atypical delays in shipping due to backorders for even the largest VENDORS. Such delays due to higher-than-normal order rates are excused.

Note that the intent here is to protect the teams against long delays in availability of parts that will impact their ability to complete their ROBOT. The *FIRST* Robotics Competition build season is only six weeks long, so the VENDOR must be able to get their product, particularly *FIRST* unique items, to a team in a timely manner.

- The business should maintain sufficient stock or production capability to fill teams orders within a reasonable period during the build season (less than 1 week). Note that this criterion may not apply to custom-built items from a source that is both a VENDOR and a fabricator. For example, a VENDOR may sell flexible belting that the team wishes to procure to use as treads on their drive system. The VENDOR cuts the belting to a custom length from standard shelf stock that is typically available, welds it into a loop to make a tread, and ships it to a team. The fabrication of the tread takes the VENDOR two weeks. This would be considered a FABRICATED ITEM, and the two weeks ship time is acceptable. Alternately, the team may decide to fabricate the treads themselves. To satisfy this criterion, the VENDOR would just have to ship a length of belting from shelf stock (i.e. a COTS item) to the team within five business days and leave the welding of the cuts to the team.
- The VENDOR makes their products available to all *FIRST* Robotics Competition teams.
- VENDORS must not limit supply or make a product available to just a limited number of *FIRST* Robotics Competition teams.
- Ideally, chosen VENDORS should have national distributors.
 - Example: distributors include Home Depot, Lowes, MSC, Radio Shack, and McMaster-Carr. *FIRST* competition events are not usually near home. When parts fail, local access to replacements is often critical.

FIRST desires to permit teams to have the broadest choice of legitimate sources possible, and to obtain COTS items from the sources that provide them with the best prices and level of service available. The intent of this definition is to be as inclusive as possible to permit access to all legitimate sources, while preventing ad hoc organizations from providing special-purpose products to a limited subset of teams in an attempt to circumvent the cost accounting rules.

8.3 ROBOT RULES

These rules establish the global robot construction and performance constraints dictated by the characteristics of the provided Kit Of Parts along with the size and weight design limits specified in this section. **Compliance with the rules is mandatory! Any ROBOT construction not in compliance with the rules (determined at inspection) must be rectified before a ROBOT will be allowed to compete.**

When reading these Rules, please use technical common sense (engineering thinking) rather than “lawyering” the interpretation and splitting hairs over the precise wording in an attempt to find loopholes. Try to understand the reasoning behind a rule.

8.3.1 General Design & Safety Rules

- <R01>** Each registered FIRST Robotics Competition team can enter ONE (1) ROBOT into the 2007 FIRST Robotics Competition. That ROBOT must be assembled using materials from the 2007 FIRST Kit Of Parts, and other allowed materials as specified in the Rules, and must fully comply with all Rules.
- <R02>** Energy used by *FIRST* Robotics Competition ROBOTS, (i.e., stored at the start of a match), can only come from the following sources:
- Electrical energy derived from the onboard 12V and 7.2V batteries
 - Compressed air stored in the pneumatic system, and stored at a maximum pressure of 120 PSI in no more than four Clippard Instruments tanks. This compressed air must be supplied by the compressor included in the Kit Of Parts, and can not come from any other source.
 - A change in the altitude of the ROBOT center of gravity.
 - Storage achieved by deformation of ROBOT parts. Teams must be very careful when incorporating springs or other items to store energy on their ROBOT by means of part or material deformation. A ROBOT may be rejected at inspection if, in the judgment of the inspector, such items are unsafe.
- <R03>** Protrusions from the ROBOT must not pose hazards to team members or event staff. If, in the judgment of the inspectors or referees, a device on the ROBOT poses a hazard (particularly puncture or impalement hazards), the team will be required to remedy the situation before the ROBOT will be allowed to play. If the ROBOT includes protrusions that form the “leading edge” of the ROBOT as it drives, and are less than one square inch in surface area, it will invite detailed inspection. For example, forklifts, lifting arms, grapplers. etc. may be carefully inspected for these hazards.
- <R04>** Exterior or exposed surfaces on the ROBOT must not present undue hazards to the team members, event staff or GAME PIECES. Reasonable efforts must be taken to remove, mitigate, or shield any sharp edges, pinch points, entanglement hazards, projectiles, extreme visual/audio emitters, etc. from the exterior of the ROBOT. Any of these potential hazards will be carefully inspected.
- <R05>** “Wedge” ROBOTS are not allowed. ROBOTS must be designed so that interaction with opposing ROBOTS results in pushing rather than tipping or lifting. Neither offensive nor defensive wedges are allowed. All parts of a ROBOT between 0 and 8.5 inches from the ground (the top of the BUMPER ZONE) that are used to push against or interact with an opposing ROBOT must be within 10 degrees of vertical. Devices deployed outside the ROBOT footprint should be designed to avoid wedging. If a mechanism or an appendage (e.g. a harvester for retrieving GAME PIECES) becomes a wedge that interferes with other ROBOTS, penalties, disabling, or disqualification can occur depending on the severity of the infraction.
- <R06>** Ramps, platforms as other mechanisms specifically designed to elevate ROBOTS during the END GAME are exempt from Rule <R05> when they are deployed in the HOME ZONE. Such devices deployed outside the HOME ZONE are not covered by this exemption.

8.3.2 Robot Physical Rules

8.2.3.1 Robot Dimensions

<R07> Prior to the beginning of the match, the ROBOT must be placed in a STARTING CONFIGURATION that fits within one of the three permitted classes of dimensions listed below:

	<u>Maximum Width</u>	<u>Maximum Depth</u>	<u>Maximum Height</u>	<u>Maximum Weight</u>
Class 1:	28 inches (71.12cm)	38 inches (96.52cm)	48 inches (121.92cm)	120 pounds (54.43Kg)
Class 2:	28 inches (71.12cm)	38 inches (96.52cm)	60 inches (152.40cm)	110 pounds (49.89Kg)
Class 3:	28 inches (71.12cm)	38 inches (96.52cm)	72 inches (182.88cm)	100 pounds (45.36Kg)

Any restraints (elastic bands, springs, etc.) that are used to restrain the ROBOT in its STARTING CONFIGURATION must remain attached to the ROBOT for the duration of the match.

<R08> The ROBOT will be inspected for compliance with the maximum permissible dimensions while in its STARTING CONFIGURATION. The ROBOT must fit within a *FIRST* Sizing Device that has inside surface dimensions as specified in Rule <R07>. Other than resting on the floor of the Sizing Device, no part of the ROBOT can break the plane of the sides or top of the Sizing Device during size inspection. The ROBOT must be self-supporting while in the Sizing Device.

<R09> At the time of inspection, the team must declare in which weight/height class (as specified in Rule <R07>) the ROBOT will be configured for the competition. Once inspected for the declared weight/height class, the ROBOT must remain within the weight/height restrictions of that class for the duration of the competition event. Modifications or changes to the configuration of the ROBOT after the start of the competition that change the weight/height class of the ROBOT will not be permitted.

<R10> At weigh-in, the basic ROBOT structure and all elements of all additional mechanisms that might be used in different configurations of the ROBOT must be weighed together. Included in the weight limit are the robot control system, back-up 7.2V battery, decorations, and all other attached parts.

- Example: A team has decided to design their “Class 1” ROBOT such that, before any given match, they may change the configuration of the ROBOT based on perceived strengths or weaknesses of an opposing ROBOT. The team accomplished this by constructing its ROBOT as a basic drive train platform plus two versions of a GAME PIECE manipulator, each manipulator being a quick attach / detach device such that either one or the other (but not both) may be part of the ROBOT at the beginning of a match. Their ROBOT platform weighs 107 lb, version A of the manipulator weighs 6 lb, and version B weighs 8 lb. Although only one version will be on the ROBOT during a match, both manipulators (and all components of the manipulators that would be used during the match) must be on the scale along with the ROBOT platform during weigh in. This would result in a **rejection** of the ROBOT because its total weight comes to 121 lb.

- <R11> For the purposes of determining compliance with the weight and volume limitations specified in Rule <R07>, these items are NOT considered part of the ROBOT and are NOT included in the weight and volume assessment of the ROBOT:
- The 12V battery and its associated half of the Anderson cable quick connect/disconnect pair (including no more than 12 inches of cable per leg, the associated cable lugs, connecting bolts, and insulating electrical tape) on board the ROBOT.
 - Any STANDARD BUMPER assemblies included on the ROBOT that are in compliance with Rule <R37>, up to a maximum of 15 pounds.
 - The FLAG is not considered part of the ROBOT. However, the flag holder specified in Rule <R15> IS considered part of the ROBOT, and is included in the weight and volume determination
 - The OPERATOR CONSOLE.

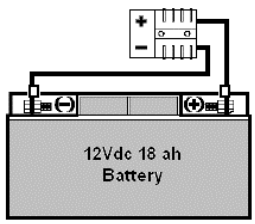
<p>NOTE</p> <ul style="list-style-type: none"> - Weight limit excludes the 12 volt battery and Anderson cable half. - Weight and volume limits exclude any STANDARD BUMPERS constructed consistent with Rule <R37>. - Weight and height limits exclude the FLAG 	 <p>12Vdc 18 ah Battery</p>
--	--

However, for all other purposes the items listed above are considered part of the ROBOT and must comply with all other applicable rules and requirements. In particular, these items are subject to the shipping deadlines specified in Section 4 and must ship in the crate with the rest of the ROBOT.

- <R12> Once the match has started, the ROBOT may assume a PLAYING CONFIGURATION that exceeds the size dimensions specified in Rule <R07>. While outside of its HOME ZONE, a ROBOT may expand up to a maximum width of 72 inches and depth of 72 inches. While entirely inside of its own HOME ZONE, there is no limit to the maximum width or depth of the ROBOT, as long as it remains entirely within the HOME ZONE. There are no height limits for a ROBOT in its PLAYING CONFIGURATION at any time after the start of the match (other than those naturally created by the ceiling height of the competition venue).

8.3.2.3 Robot Visibility

- <R13> ROBOTS must display their school name, and primary sponsor name and/or logo whenever the ROBOT is on the field (including practice sessions). The support provided by the corporate sponsors and mentors on your team is important, and is to be acknowledged with the appropriate display of their names/logos on the exterior of the ROBOT.
- <R14> The judges, referees, and announcers must be able to easily identify ROBOTS by Team Number. Teams must display their Team Number in four locations at approximately 90-degree intervals around the perimeter of the ROBOT. *The numerals must be at least 4 inches high, at least in 3/4- inch stroke width and in a contrasting color from its background. Team Numbers must be clearly visible from a distance of not less than 100 feet.*

<R15> ROBOTS must use one of the two FLAGS provided at the event queuing location to display their ALLIANCE color (red or blue). The FLAG must be held in a flag holder mounted on the ROBOT. The only acceptable flag holder is a 12 inch long piece of 1/2" ID Schedule 40 PVC tube. The tube must be a single, contiguous piece, must be capped with a commercial PVC pipe cap cemented at one end. The tube can not have any "lightening holes" or other modifications other than mounting holes (paint or other decorative surface finishes are permitted). The flag holder must be permanently mounted to the ROBOT such that when the ROBOT is in any PLAYING CONFIGURATION and the FLAG is in the flag holder, the FLAG is approximately vertical and the top of the FLAG is a minimum of 18 inches higher than any point on the central mass or structure of the ROBOT (note: ROBOT arms, appendages, and extensions may temporarily intrude into the space above the top of the ROBOT and exceed this height of the FLAG – this a normal part of game play, and will not be considered a violation of this rule). The intent of this rule is to insure that the FLAG must be easily seen from any side during the entire match play.

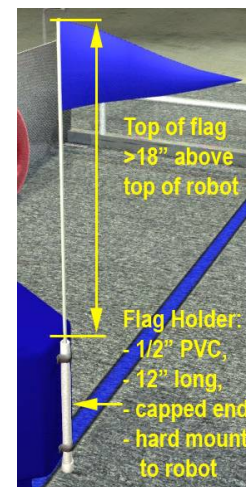

<R16> ROBOTS must use the panel signal device provided in the Kit Of Parts. Field personnel will use the panel signal device during the matches for diagnostic purposes. It must be mounted on the ROBOT such that it is easily visible while standing three feet in front of the ROBOT in its' STARTING CONFIGURATION. Instructions for connecting the panel signal device are provided on the *FIRST* website at www.usfirst.org/frc/2007/manual. The Robot Controller directly powers and controls the panel signal device. The user has no control over the panel signal device and no programming is required.

8.3.3 Fabrication Schedule

One of the fundamental values of *FIRST* is the concept of "gracious professionalism." *FIRST* recognizes that it is the responsibility of each team to abide by the fabrication schedule rules defined below. As compliance with these rules takes place outside of the competition venues, *FIRST* is not able to directly monitor compliance. We are relying upon the honor, integrity, and professional behavior of each team to recognize and abide by the fabrication schedule rules. Teams must design and construct their ROBOT within the schedule constraints defined below.

Note that the schedule rules apply to both hardware and software development. Hardware and software design processes are thought-intensive activities, and team members are likely to continue to consider and analyze their designs long after the ROBOT is shipped. Teams can not be prevented from thinking about their hardware and software designs, and it is not our intention to do so. However, the timeline permitted for the development of the actual competition version of the ROBOT is severely, and intentionally, restricted. Pondering software issues to be resolved, researching general case solutions, discussing solutions with teammates, collecting raw materials, sketching mechanisms, preparing tools, and outlining high-level descriptions of software algorithms are all reasonable activities outside of the scheduled build periods. But completing detailed dimensioned drawings of parts, and any actual fabrication of any hardware items intended to go on the actual competition ROBOT is prohibited outside of the approved fabrication periods. On the software side, developing detailed pseudo-code, writing actual lines of code, verification of syntax, final debugging, etc would all be considered development of the final software implementation, and must be completed during the approved fabrication periods.

- <R17>** Prior to the Kick-off: Before the formal start of the Robot Build Season, teams are encouraged to think as much as they please about their ROBOTS. They may develop prototypes, create proof-of-concept models, and conduct design exercises. Teams may gather all the raw stock materials and COTS COMPONENTS they want. But absolutely no fabrication or assembly of any elements intended for the final ROBOT is permitted prior to the Kick-off presentation.
- <R18>** During the Build Season: During the period between the Kick-off and ROBOT shipment deadline, teams are to design and fabricate all the COMPONENTS and MECHANISMS required to complete their ROBOT. They are encouraged to use all the materials, sources and resources available to them that are in compliance with the rules of the 2007 *FIRST* Robotics Competition. When the ROBOT shipment deadline arrives, all work on the ROBOT must cease and the ROBOT must be placed in a “hands-off” condition. The entire ROBOT (including all FABRICATED ITEMS intended for use during the competition in alternative configurations of the ROBOT) and OPERATOR CONSOLE must be crated and out of team hands by the shipment deadline specified in Section 4.5.1.1.
- <R19>** During the “FIX-IT WINDOWS” following the shipment of the ROBOT: During this period, all teams may utilize one or two 5-hour FIX-IT-WINDOWS to manufacture SPARE and REPLACEMENT PARTS and develop software for their ROBOT at their home facility. Fabrication of UPGRADE PARTS is not permitted during this period. The timing of these “FIX-IT WINDOWS” is at the discretion of the team, but all work must be completed by 5:00pm on the Friday following the ROBOT shipment deadline. Teams may manufacture all the SPARE and REPLACEMENT parts they want, but the amount of parts they can bring to a competition event is limited (as specified in Rule <R31>).

The intent of the FIX-IT WINDOWS is to permit teams to prepare parts that have, or are likely to, become damaged during the course of a competition event, so they may continue to participate. Teams do not have direct access to their ROBOT during these periods, and must rely on information they generated and documented during the design and build process to determine the fit and function of any parts developed during FIX-IT WINDOWS. This is true for both hardware and software.

- <R20>** Prior to the competitions: After the close of the “FIX-IT WINDOWS” and prior to the competition, the team must put down their tools, cease fabrication of ROBOT parts, and cease all development of ROBOT software. Take this opportunity to rest, recover from the build season, and relax. Teams may scout other teams, gather and exchange information, develop game-playing strategies, collect raw materials, prepare tool kits, plan how to make repairs, etc. in preparation for the upcoming competitions. But no construction or fabrication of any hardware, or development of any software, is allowed.
- <R21>** At the competitions: Teams are allowed to repair, modify or upgrade their competition ROBOT while participating in a competition event. To support this, teams may bring SPARE, REPLACEMENT and UPGRADE PARTS and COTS items to the competitions (within the limits specified in Rules <R30> and <R31>). Work can only be done on-site in the Pits or at any facility made available to all teams at the event (e.g., in a team’s repair trailer or a local team’s shop offered to all teams to use). Fabrication may be done when the Pit area is open for normal operations during the period starting with the opening of the Pit area on Thursday and ending at 4:00PM on Saturday. All work must be completed when the Pit area closes each evening. Parts cannot be removed from the competition site and retained overnight after the Pit area closes.

<R22> During the “FIX-IT WINDOW” following each Regional Competition weekend: During this period, all teams (not just those teams attending a Regional Competition) may utilize one or two 5-hour FIX-IT-WINDOWS to manufacture SPARE, REPLACEMENT and UPGRADE PARTS and develop software for their ROBOT at their home facility (not at the competition site). The timing of these “FIX-IT WINDOWS” is at the discretion of the team, but all work must be completed between the **opening of the Competition (at 8:30 am on the Thursday of the Competition weekend) and 8:30 am on the Thursday** following the Competition weekend. At the conclusion of a regional competition event, teams may take a limited amount of broken or malfunctioning COMPONENTS or MECHANISMS back to their home facility to make SPARE or REPLACEMENT PARTS. The purpose of this rule is to allow teams to make critical repairs to existing parts to enable them to compete in following events. The intent of this rule is not to have teams take their entire ROBOT back home and make large-scale revisions or upgrades to the ROBOT. Teams may manufacture and/or repair all the parts they want, but the amount of parts they can bring to the competition event is limited (as specified in Rule <R31>).

8.3.4 Robot Material Utilization Rules

- <R23> Robots entered into the 2007 *FIRST* Robotics Competition must be fabricated and/or assembled from COMPONENTS, MECHANISMS and COTS items that are constructed from:
- Items provided in the *FIRST* supplied Kit Of Parts (or their exact replacement part)
 - Allowed Additional Parts and Materials as defined in this section in quantities consistent with the Cost Accounting Rules (found in Section 8.3.4.3).
- <R24> FABRICATED ITEMS from ROBOTS entered in previous *FIRST* competitions can not be used.
- <R25> Teams participating in the 2007 *FIRST* Robotics Competition that are located outside North America may not be able to acquire the exact part (as identified by specific part numbers) or materials of the specified dimensions as defined in these rules. In such situations, international teams must submit a request for approval of nearest-equivalent parts (e.g. nearest metric equivalent, etc.) to *FIRST* Headquarters. *FIRST* will determine suitability of the part. If approved, a confirming e-mail will be sent to the team. The team must bring a copy of the e-mail to any competition event to verify that the use of an alternate part has been approved.
- <R26> Individual COMPONENTS or MECHANISMS retrieved from previous ROBOTS and used on 2007 ROBOTS must have their un-depreciated cost included in the 2007 robot cost accounting, and applied to the overall cost limits.
- <R27> Motors, pumps, and, Robot Controllers from previous robots can not be used in addition to those provided in the 2007 Kit Of Parts. They may be used as direct one-to-one SPARE PARTS for those provided if the provided part fails or is damaged. They can only be used if they are identical to the part being replaced. Note that the Fisher-Price motor found in the 2007 Kit Of Parts (Part number 00968-9012) is different from the Fisher-Price motors used in most previous *FIRST* competitions. Only the Fisher-Price 00968-9012 motor may be used as a SPARE PART for the Fisher-Price motors provided in the 2007 Kit Of Parts.

- <R28> COTS ITEMS that are generally available may be used on the ROBOT. COTS ITEMS from ROBOTS entered in previous FIRST competitions or COTS ITEMS that are no longer commercially available may be used under the following conditions:
- ° The item must be unmodified, and still in its original condition as delivered from the VENDOR
 - ° The item must not be a part custom made for the *FIRST* competition and provided in a previous FRC Kit Of Parts (e.g. 2006 FRC transmissions, custom-made motor couplers, custom sensor strips, IFI CMUcam II modules, etc. are not permitted)
 - ° The item must satisfy ALL of the rules associated with materials/parts use for the 2007 *FIRST* Robotics Competition
- <R29> Only Innovation First Incorporated “Victor 884” speed controllers and “Spike” relay modules are permitted. Other makes and models of relay modules and speed controllers (including the Victor 883 and 885 speed controllers) cannot be used.
- <R30> Teams may acquire and bring an unlimited amount of COTS items to the competitions to be used to repair and/or upgrade their ROBOT at the competition site.
- <R31> Teams may bring a maximum of 25 pounds of custom FABRICATED ITEMS (SPARE PARTS, REPLACEMENT PARTS, and/or UPGRADE PARTS) to each competition event to be used to repair and/or upgrade their ROBOT at the competition site. All other FABRICATED ITEMS to be used on the ROBOT during the competition must arrive at the competition venue packed in the shipping crate with the ROBOT.
- <R32> MECHANISMS or COMPONENTS on the ROBOT must not pose obvious risk of entanglement. If, in the judgment of the inspectors, a device on the ROBOT poses an entanglement risk then the team will be required to remedy the situation before the ROBOT will be allowed to play. If the structure of a COMPONENT permits easy penetration by an object less than four square inches in cross section, it will invite detailed inspection. Willful entanglement actions are addressed in Rules <G37> and <G38> in **Section 7.3.4 – Robot Operations** of “The Game” section.
- Note: nets, loose rope or wire, voluminous sheets of fabric, etc. may be carefully inspected for these hazards. A 1/8” x 1/8” tight-mesh net (or very loose mesh fabric, depending on your point of view) may be a reasonable material that would not automatically pose an entanglement hazard. However, any flexible material has the potential to become an entanglement hazard if it is not firmly attached to an appropriate structure or left in a loose, voluminous configuration. Therefore, you must use your best judgment to determine if your particular use of the material will pose an entanglement hazard. However, actual performance on the playing field will determine if the potential for entanglement is significant or not.
- <R33> No devices or decorations are permitted on the ROBOT that are intended to jam or interfere with the operation of the vision system (i.e. changing ROBOT color to confuse opponent’s vision system).

<R34> ROBOT wheels, tracks, and other parts intended to provide traction on the playing field may be purchased or fabricated (“traction devices” include all parts of the ROBOT that are designed to transmit any propulsive and/or braking forces between the ROBOT and the playing field). In no case will traction devices that damage the carpet or other playing surfaces be permitted. Traction devices can not have surface features such as metal, sandpaper, hard plastic studs, cleats, or other attachments. Anchors (i.e. devices that are deployed/used to keep one’s ROBOT in one place and prevent it from being moved by another ROBOT) can not use metal in contact with the carpet or other playing surfaces to “stay put.” Gaining traction by using adhesives or Velcro-like fastener material is not allowed.

<R35> Adhesive backed tapes are NOT allowed except as follows:

- Velcro tape, any hook and loop tape or double-sided sticky foam may be used for attaching components to the ROBOT.
- Reflective tape may be used with optical sensors in small amounts.
- Adhesive backed tape and labels may be used for labeling purposes on wires, cables, pneumatic lines, etc.
- Electrical tape may be used as an electrical insulator.

<R36> Lubricants may be used only to reduce friction within the ROBOT. Lubricants shall not be allowed to contaminate the playing field or other ROBOTS.

<R37> Teams are strongly encouraged to use bumpers on their ROBOTS. Bumpers can reduce damage to ROBOTS when they contact another ROBOT or field elements. Teams may choose to use STANDARD BUMPERS or custom bumper designs. STANDARD BUMPERS have several advantages, such as being excluded from the calculation of the ROBOT weight and volume limitations specified in Rule <R07>. TEAMS that choose to use STANDARD BUMPERS, will have both a more robust ROBOT and the traction advantage of a heavier ROBOT. Alternately, TEAMS may develop custom bumper designs for use on their ROBOTS. However, custom bumper designs are NOT eligible for the weight/volume exclusion offered for STANDARD BUMPERS. All custom bumper designs are considered part of the ROBOT, and must satisfy the constraints listed in Rule <R07> (as well as all other rules). STANDARD BUMPERS must be designed as described below. Any bumper design inconsistent with these design elements will be considered a custom bumper.

- STANDARD BUMPERS must be designed as shown in figures 8-1 and 8-2. This is the only acceptable design for STANDARD BUMPERS.
- STANDARD BUMPERS must be removable so that they can be weighed separately from the ROBOT. STANDARD BUMPERS must be attached to the ROBOT with a bolt-and-fastener system to form a rigid, robust connection to the ROBOT structure (i.e. not attached with Velcro!).

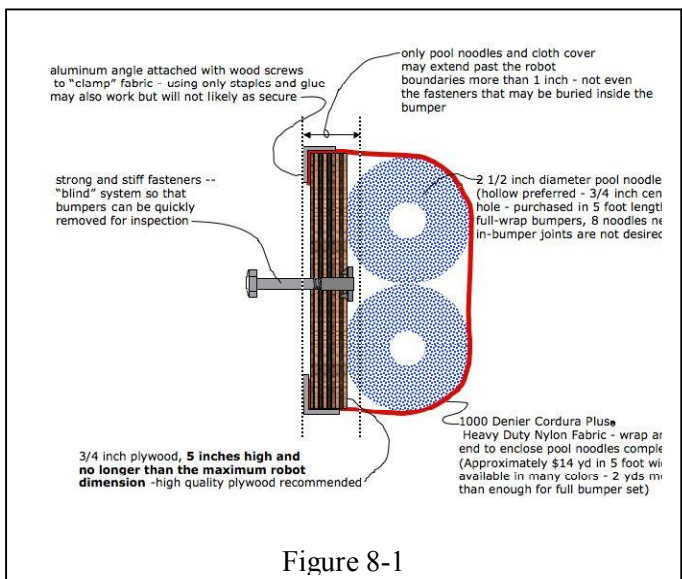
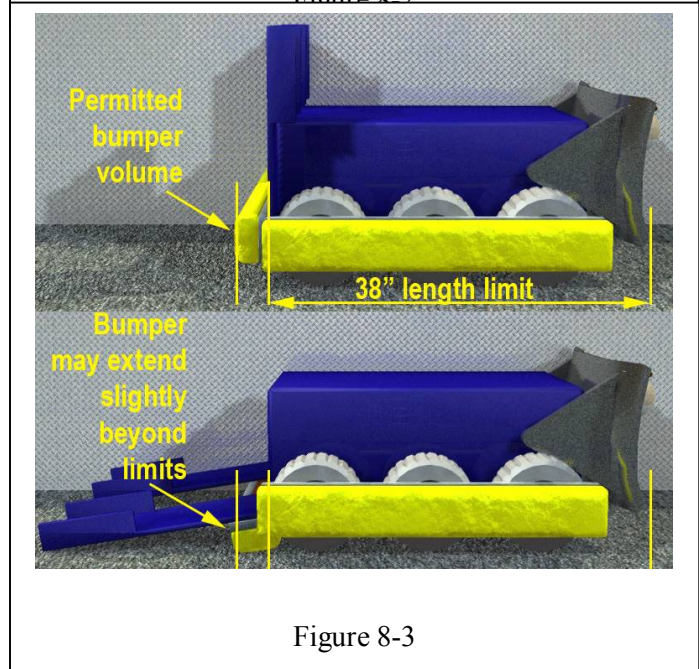
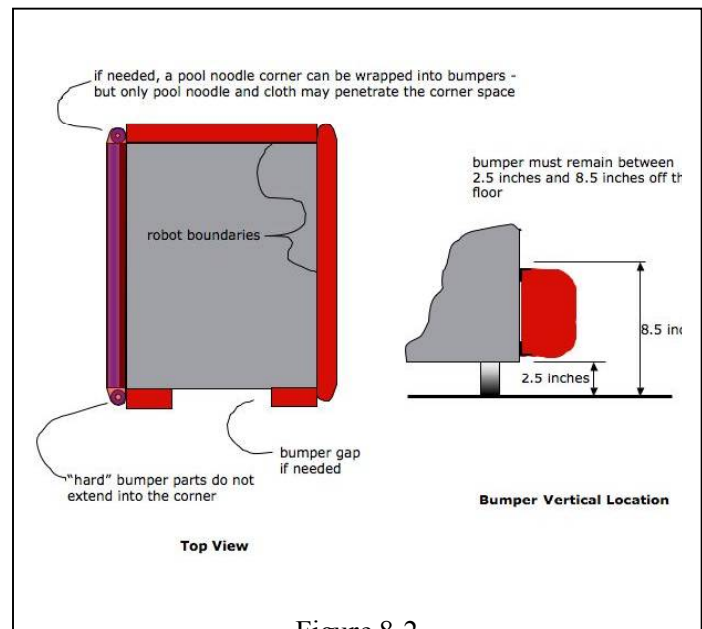

Figure 8-1

- STANDARD BUMPERS must weigh, in total, no more than 15 pounds including any fasteners that attach them to the ROBOT.
- STANDARD BUMPERS do not have to surround the entire perimeter of the ROBOT, and may be segmented. However, STANDARD BUMPERS must be a minimum of 6 inches in length and can not include sections that weigh more than 3 ounces per inch (i.e. no short bumpers with giant heavy fasteners).
- STANDARD BUMPERS must use a stacked pair of 2-1/2 inch “pool noodles” as the bumper material.
- STANDARD BUMPERS must use 3/4 inch plywood backing 5 inches tall as the bumper structure to attach the bumper (“pool noodles”) to the ROBOT.
- STANDARD BUMPERS must be covered with a tough smooth cloth (1000 denier Cordura Plus® strongly recommended).
- In the STARTING CONFIGURATION, STANDARD BUMPERS may extend outside the horizontal dimensions for the ROBOT (as specified in Rule <R07>) by up to a maximum of 3-1/2 inches per side. Nothing other than pool noodles and cloth can extend more than 1 inch beyond the ROBOT boundaries.
- Hard bumper parts MUST NOT extend into the corners.
- STANDARD BUMPERS must remain within the BUMPER ZONE when the ROBOT is resting on the floor in PLAYING CONFIGURATION. They can not be articulated or moved outside of the BUMPER ZONE. The one exception to this is STANDARD BUMPERS may be within or below the BUMPER ZONE during the END GAME if the ROBOT is in its HOME ZONE (see Figure 8-3).
- For the purposes of the shipping deadlines, STANDARD BUMPERS are considered part of the ROBOT, and must be shipped in the crate with the ROBOT.



Bumper height has been specified so that ROBOTS will make contact bumper-to-bumper and so that the GAME PIECES will be pushed rather than pulled under the ROBOTS. Note that ROBOT wheel/tracks must be properly positioned relative to any bumpers to avoid interference issues when elevating ROBOTS during the END GAME. As bumper mounts are being designed, please

consider how the ROBOT will be carried (bumpers typically do not make good handles!). Also, note that the use of STANDARD BUMPERS may preclude the use of other technologies in their out-of-the-box configurations. Teams will need to carefully consider the interactions between available bumper options and other elements of their ROBOT design.

8.3.4.1 Kit Of Parts Rules

<R38> So that every ROBOT'S maximum power level is the same, the motors in the Kit Of Parts can **not** be modified in any way, except as follows:

- The mounting brackets and/or output shaft/interface of the motors may be modified to facilitate the physical connection of the motor to the ROBOT and actuated part.
- The gearboxes for the Fisher-Price, and Globe motors are not considered "integral" and may be separated from the motors. FIRST will not provide replacements for parts that fail due to modification.
- The electrical input leads on the motors may be trimmed to length as necessary.

The intent is to allow teams to modify mounting tabs and the like, not to gain a weight reduction by potentially compromising the structural integrity of any motor. The integral mechanical and electrical system of the motor is not to be modified.

<R39> Teams may replace lost or damaged Kit Of Parts COMPONENTS only with identical COMPONENTS of the same material, dimensions, and treatment.

<R40> Materials in the Kit Of Parts can not be changed chemically with the following exceptions:

- Rope ends may be singed to prevent loose ends or to bind them together
- Metal may be heat treated
- Metal may be plated or anodized

8.3.4.2 Additional Parts and Materials Rules

Part of the purpose of the FIRST Robotics Competition is to provide team members with the experience of conceptualizing, designing and constructing their own solution to the challenge posed by the game. This must be a consideration when obtaining MECHANISMS and COTS items as additional parts to use on the ROBOT.

This intent is clearly met when a team obtains a MECHANISM or COTS items that was designed for non-FIRST other than robotic competition purposes, and then modifies or alters it to provide functionality for the ROBOT. For example, if a team obtains a gearbox from a power drill and modifies it to use on the ROBOT, they gain insight into the design of the original gearbox purpose, learn to characterize the performance of the original design, and implement the engineering design process to create their customized application for the gearbox.

However, COTS items that have been specifically designed are in and of themselves as a solution to portion of the FIRST Robotics Competition challenge may or may not fit within the FRC intent, and must be carefully considered. If the item provides general functionality that can be utilized in any of several possible configurations or applications, then it is acceptable (as the teams will still have to design their particular application of the item). However, COTS items that provide a complete "pre-packaged" solution for a major ROBOT function (e.g. a complete manipulator assembly, pre-built pneumatics circuit, or full mobility system) that require no effort other than just bolting it on to the ROBOT are against the intent of the competition, and will not be permitted.

In addition to the items directly supplied in the 2007 Kit Of Parts, teams are allowed to use the following parts and materials in the construction of their ROBOTS.

- <R41> The use of an additional part or material shall not violate any design rule.
- <R42> Additional parts shall not be made from hazardous materials or be unsafe. Materials classified as hazardous by their MSD Sheets are explicitly prohibited. Note that this precludes the use of any flammable gases, including hydrogen gas used by the Green Machine pilot program. Teams should provide MSD Sheets for any materials they use that might be considered questionable during ROBOT inspection.
- <R43> Additional parts must be generally available from suppliers such that any other *FIRST* team, if it so desires, may also obtain them at the same price. A specific device **fabricated by a team** from non-2007 Kit Of Parts materials for their use does not have to be available to others; however, the materials it is made from must be available to other teams.
- <R44> The costs of all additional parts and materials must be in compliance with the Cost Accounting Rules of Section 8.3.4.3.
- <R45> Items specifically permitted on 2007 FRC ROBOTS include:
- Additional HITEC HS-322HD Servos.
 - Additional Victor 884 speed controllers and Spike relay modules, as needed.
 - One additional 4-slot Maxi-block circuit breaker panel and utilize it on their 2007 ROBOT in addition to, or in replacement of, the circuit breaker panels provided in the Kit Of Parts.
 - One or two additional 2-1/2" CIM motors (part #FR801-001 and/or M4-R0062-12) in addition to those provided in the Kit Of Parts. This means that up to four, and no more, 2-1/2" CIM motors can be used on the ROBOT.
 - One additional 3" CIM "Minibike" motor (part #FR801-005). This means that up to two, and no more, 3" CIM "Minibike" motors can be used on the ROBOT.
 - Additional solenoid valves, air cylinders, and connecting fittings.
 - One or two additional Clippard air storage tanks (Clippard Part Number AVT-32-16), equivalent to those provided in the kit. This means that up to four, and no more, Clippard air storage tanks can be used on the ROBOT.
 - Pneumatic pressure relief valves identical to those provided in the Kit Of Parts (Parker Part Number PV609-2).
- <R46> Items specifically PROHIBITED from use on the robot during competition matches include:
- Primary 12v batteries different from those provided in the KOP
 - More than one primary battery, or more than one back-up battery
 - Circuit breakers different from those provided in the Kit Of Parts. Note: the Snap Action brand circuit breakers provided have unique "trip" characteristics. No substitute brands are permitted.
 - Fuse panels different from those provided in the Kit Of Parts.

- Electric motors different from, or in addition to, those in the Kit, with the exception of those specifically permitted by Rule <R45>.
- Any air compressor other than the one provided in the Kit Of Parts.
- Hydraulic fluids or hydraulic components.
- Lasers of any type.
- Speakers, sirens, air horns, or other audio devices that generate sound at a level sufficient to be a distraction or hindrance affecting the outcome of a match.
- Electric solenoid actuators (note: electric solenoid actuators are NOT the same as pneumatic solenoid valves – the latter are permitted, the former are not).

<R47> Additional electronic components for use on the ROBOT must be either COTS items, or assembled from COTS items. Additional electronic components include any object that intentionally conducts electricity, other than IFI relays and speed controllers, wires, connectors, solder, and fabricated printed circuit boards.

<R48> Refer to the 2007 Parts Use Flowchart to help determine the legality of a part.

START HERE
May we use a part or material on our robot?

2007 Parts Use Flowchart

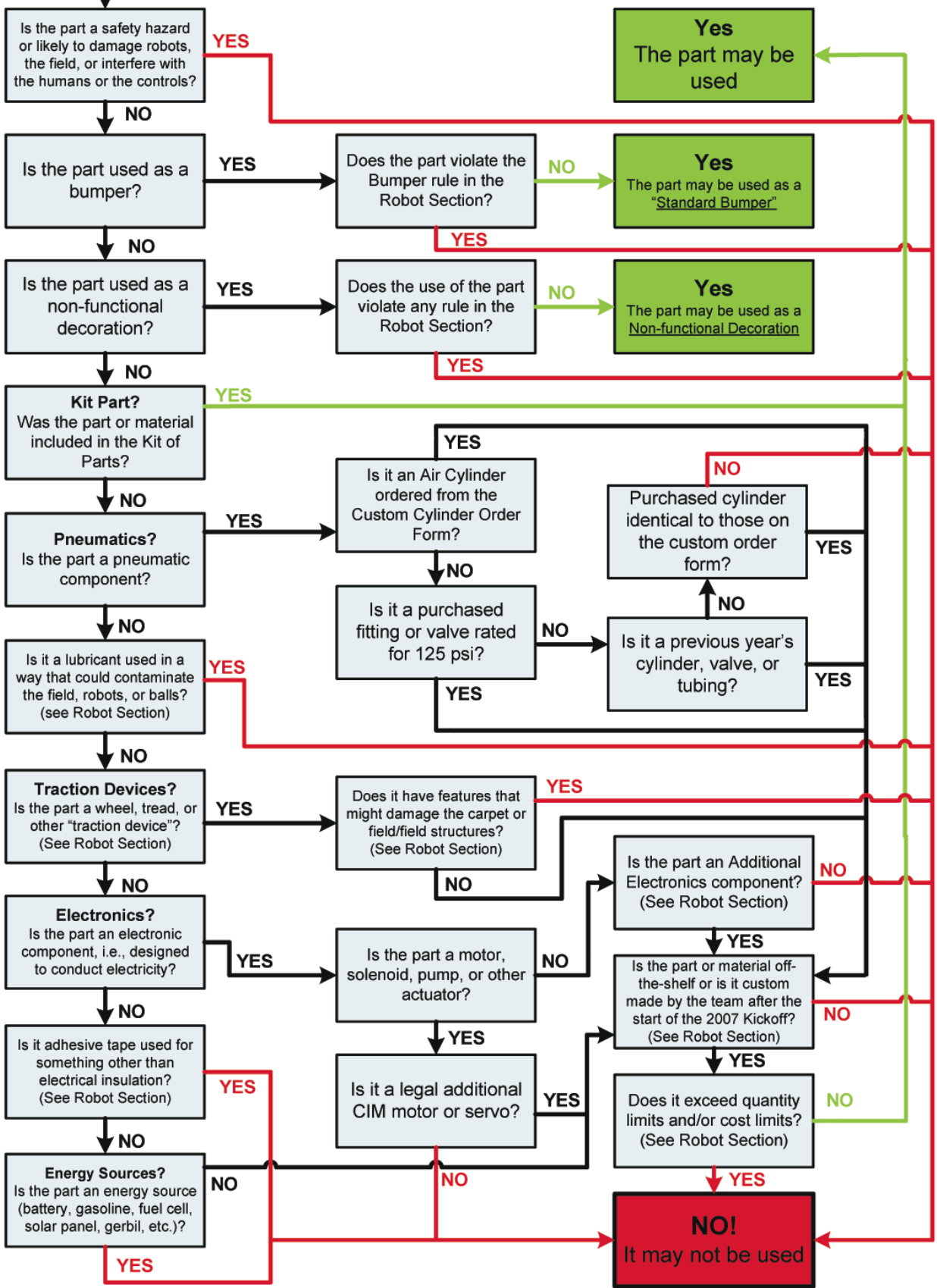

8.3.4.3 Cost Accounting Rules

- <R49> The costs of all non-2007 Kit parts and materials used in the construction of a ROBOT (as defined in Section 8.1.1) must be recorded (in US dollars) by the team, and a list of all such items and their costs presented at ROBOT inspection.
- <R50> All costs are to be determined as explained in Section 8.3.4.4 - Additional Parts - Cost Determination.
- <R51> The total cost of all non-Kit Of Parts items must not exceed \$3,500.00 USD. No individual item shall have a value of over \$400.00. The total cost of components purchased in bulk may exceed \$400.00 USD as long as the cost of an individual component does not exceed \$400.00. The following items are EXCLUDED from the total cost calculation:
- The cost of any non-functional decorations
 - The cost of individual fasteners, adhesives, or lubricants, unless any one component exceeds \$1.00
 - The costs of SPARE PARTS. A SPARE PART used as a direct replacement for a failed or defective ROBOT part (either Kit part or non-Kit part) that has already been included in the cost accounting is covered by the accounting for the original part
 - All costs for the construction of the OPERATOR CONSOLE
- <R52> The costs of additional non-spare robot control system components obtained from Innovation First Inc. are to be included in the above \$3500.00 limit.

8.3.4.4 Additional Parts - Cost Determination

The "cost" of each additional item is calculated based on the following criteria, as applicable:

- The purchase price of a COTS item offered for sale by a VENDOR to any customer.
- The total cost (materials + labor) of an item you pay someone else to make.
 - Example: A team orders a custom bracket fabricated by a VENDOR to the team's specification. The VENDOR'S material cost and normally charged labor rate apply.
- The fair market value of an item obtained at a discount or as a donation. Fair market value is that price at which the supplier would normally offer the item to other customers. Also considered to be "fair market value" are the discounted prices offered to all teams by suppliers with established relations with *FIRST*.
 - Example: Special price discounts from MSC Industrial Supply Co. and Terminal Supply Co. are being offered to all *FIRST* teams. The discounted purchase price of items from these sources would be used in the additional parts accounting calculations.
- The cost of raw material obtained by a team + the cost of non-team labor expended to have the material processed further. Labor provided by team members and/or by a recognized team sponsor whose employees are members of the team does not have to be included. Note: it is in the best interests of the teams and *FIRST* to form relationships with as many organizations as possible. Teams are encouraged to be expansive in recruiting and including organizations in their team, as that exposes more people and organizations to *FIRST*. Recognizing supporting companies as sponsors of, and members in, the team is encouraged - even if the involvement of the sponsor is solely through the donation of fabrication labor.

- Example: A team purchases steel bar stock for \$10.00 and has it machined by a local machine shop. The machine shop is not considered a team sponsor, but donates two hours of expended labor anyway. The team must include the estimated normal cost of the labor as if it were paid to the machine shop, and add it to the \$10.00.
- Example: A team purchases steel bar stock for \$10.00 and has it machined by a local machine shop that is a recognized sponsor of the team. The machinists are considered members of the team, so their labor costs do not apply. The total applicable cost for the part would be \$10.00.
- The cost of items purchased in bulk or large quantities may be prorated on the basis of the smallest commonly available unit that satisfies the need for the item.
 - Example: A team purchases a 4' x 4' sheet of aluminum, but only uses a piece 10" x 10" on their ROBOT. The team identifies a source that sells aluminum sheet in 1' x 1' pieces. The team may cost their part on the basis of a 1' x 1' piece, even though they cut the piece from a larger bulk purchase. They do not have to account for the entire 4' x 4' bulk purchase item.
- Shipping costs of Non-Kit items are not counted.
- COMPONENTS or MECHANISMS that teams purchase to replace Kit Of Parts items that were not received from *FIRST* are not subject to the cost limitation (i.e., should not be charged against the \$3,500.00 robot limit).
- If the item is part of a modular system that can be assembled in several possible configurations or applications, then each individual module must fit within the price constraints defined in Rule <R51>. If the modules are designed to assemble into a single configuration, and the assembly is functional in only that configuration, then the total cost of the complete assembly including all modules must fit within the price constraints defined in Rule <R51>.

8.3.5 Electrical System Rules

- <R53> The only legal main source of electrical energy on the ROBOT during the competition is the 12VDC non-spillable lead acid battery provided in the 2007 Kit Of Parts. That 12V battery is the MK Battery, ES17-12. Additional batteries may be purchased through a local MK Battery supplier. Teams may use other equivalent 12V batteries during development, testing and practice matches. However, during the qualifier and elimination matches, only the MK Battery, ES17-12 can be used (**this means NO pre-2007 batteries can be used during qualification and elimination matches at any official 2007 *FIRST* competition**).
- <R54> The ES17-12 can only be charged between matches by a 6-ampere rated automatic battery charger. When recharging the Kit Of Parts batteries, either the charger provided by *FIRST* or an automatic charger with an equivalent charging current rating may be used.
- <R55> The 7.2v "backup" battery is considered an integral part of the Robot Controller, and can not be used for any other purpose.
- <R56> The 7.2v backup battery may be charged on or off the ROBOT. When off the ROBOT, the battery is to be charged with a 7.2V backup battery charger. When mounted on the ROBOT, the backup battery may only be charged from the 12VDC primary battery using the Battery Charging Circuit available from Innovation First Inc. (note: IFI will provide the design for this circuit on the IFI website, however teams must obtain the parts for this circuit and assemble it themselves). The use of this circuit is strongly encouraged.

<R57> The 12V battery, the main 120-amp circuit breaker, the power distribution block, and circuit breaker distribution panels must be connected as shown in the *2007 Power Distribution Diagram*. In particular:

- The battery must be connected to the ROBOT power system through the use of the Anderson Power Products (APP) connector.
- The APP connector must be attached to the battery with either the copper lugs provided in the FCI Burndy Bag or appropriate crimp-on lug connectors.
- The battery terminals and the connecting lugs must be insulated with shrink tubing and/or electrical tape.
- The main 120-amp circuit breaker must be directly connected to the hot (+) leg of the ROBOT-side APP connector. Only one 120 amp main circuit breaker is allowed. This breaker must not be bypassed.
- The power distribution block must be directly connected to the APP connector and main 120-amp circuit breaker. No other loads may be connected to the main 120-amp circuit breaker.
- All circuit breaker distribution panels must be connected directly to the power distribution block. No intermediate connections are permitted.
- Additional lengths of #6 red and #6 black wire may be used to reach the panels as needed to make the above connections.
- Circuit breakers must be accessible for inspection at each *FIRST* Robotics Competition event.

<R58> All wiring and electrical devices must be electrically isolated from the ROBOT frame; the ROBOT frame must not be used to carry electrical current (this isolated ground arrangement is necessary due to polarity reversals that occur under certain operating conditions such as during motor direction reversals).

<R59> All 12v electric power used on the ROBOT must be obtained from the load terminals of the circuit breaker distribution panels. Each branch circuit must be protected using the appropriate value circuit breaker as specified in Section 8.3.9.1 "Circuit Breaker/Fusing Rules."

8.3.6 Custom Circuit Rules

<R60> The use of additional electronics is intended to allow teams to construct custom circuits for their ROBOTS. The custom circuits may be used to indirectly affect the robot outputs by providing enhanced sensor feedback to the Robot Controller to allow it to more effectively decide how to control the ROBOT. In addition to the required branch power circuit breaker, smaller value fuses may be incorporated in the custom circuits for additional protection.

<R61> All outputs from the custom circuits must connect to the Robot Controller or to other custom circuits. If connected to the Robot Controller, they must connect through the analog inputs, digital I/O, TTL Serial Port, or Program Port only. Custom circuits can not connect to the Robot Controller through any other ports. Custom circuit outputs can not connect to speed controllers, relay modules, or pneumatic valves.

<R62> Inputs to custom circuits can be connected to the following sources:

- Branch circuit breaker outputs

- Speed controller or relay module outputs
- PWM, relay or digital outputs on Robot Controller
- Switches, potentiometers, accelerometers, sensors, and other additional permitted electronics.

<R63> Custom Circuits can **not**:

- Interfere with the operation of other ROBOTS.
- Directly alter the power pathways between the battery, fuse blocks, speed controllers, relays, or motors. Custom high impedance voltage monitoring or low impedance current monitoring circuitry connected to the ROBOT'S electrical system is acceptable, because the effect on the ROBOT outputs should be inconsequential.
- Directly affect any output devices on the ROBOT, such as by providing power directly to a motor, supplying a PWM signal to a speed controller or supplying a control signal to a relay module.
- Be used for wireless communication, such as sending or receiving a signal to and/or from the alliance station.
- Connect to the radio or tether ports on the Robot Controller

8.3.7 Control System Rules

<R64> ROBOTS must be operated via the wireless, programmable Innovation First 2007-Robot Control System.

<R65> The control system is provided to allow wireless control of the ROBOTS. The Operator Interface, Robot Controller, speed controllers, relay modules, radio modems, batteries, battery charger, AC adapter, and 9-pin cables can not be tampered with, modified, or adjusted in any way, (tampering includes drilling, cutting, machining, gluing, rewiring, etc.) with the following exceptions:

- Dip switches on the Operator Interface may be set as appropriate.
- User programmable code in the Robot Controller may be customized.
- Speed controllers may be calibrated as described in owner's manuals.
- The fuse on the Spike relay for the air compressor may be replaced with a 20 Amp Snap-Action circuit breaker.

<R66> The radio modems provided in the 2007 Kit Of Parts are the only permitted method for communicating with the ROBOTS during the competition. Radio modems from previous *FIRST* competitions can not be used. The radio modem must be connected directly to the Robot Controller using one of the DB-9 cables provided in the 2007 Kit Of Parts. No other form of wireless communications can be used to communicate to, from or within the ROBOT (e.g. no Bluetooth devices are permitted on the ROBOT).

<R67> Teams are responsible for any software bugs introduced into the Robot Controller's control program when using a custom program or for any unwanted or unanticipated ROBOT behavior when using additional electronics.

- <R68> The Robot Controller must be positioned within the ROBOT so that its indicator lights can be seen during inspection and when standing three feet in front of the ROBOT while the ROBOT is in the STARTING CONFIGURATION at the beginning of a match. This will greatly facilitate analysis in case of problems.
- <R69> All electrical loads (motors, actuators, compressors) must be controlled by relay or PWM output signals sent by the Robot Controller to relay modules or speed controllers. Every speed controller and relay module must be connected via PWM cable to the Robot Controller, and be controlled by signals provided by the Robot Controller. They can not be controlled by signals from any other source.
- <R70> The team number settings on the Operator Interface must be set to the team number assigned to the team by *FIRST*, then the Robot Controller must be tethered to the Operator Interface to transfer the Team Number setting to the Robot Controller. This must be done every time changes are made to the team number setting on the Operator Interface.
- <R71> Do not connect 12Vdc power, relay module outputs, speed controller outputs, or PWM outputs to the analog or digital I/O on the Robot Controller.
- <R72> All outputs from the sensors and additional electronics circuits used on the ROBOT must be connected directly to other custom circuits or the analog or digital I/O on the Robot Controller. It is acceptable to wire switches used as sensors in series or parallel with each other.
- <R73> The 7.2V Robot Control backup battery must be connected to the Robot Controller as described in the Robot Controller manual. The 7.2v battery should be charged to at least 7.0v before entering a match. As a replacement for the *FIRST* supplied battery, any other commercially available 7.2V NiCad battery pack may be used.
- <R74> A remote reset and remote programming switch may be wired to the Robot Controller RESET/PROG header. Any switch may be used. See the *Robot Controller Reference Guide* for wiring information.
- <R75> Digital outputs of the Robot Controller may be connected directly to brake/coast headers on the speed controllers to permits programmable control of this speed controller function. The brake/coast header on the speed controller may NOT be connected to any other circuit or input.
- <R76> Unaltered software modules developed during prior competitions can not be directly reused. Just as designs for hardware COMPONENTS may be reused from one year to the next, software algorithms and designs may be reused. However, the specific lines of code must be customized for each ROBOT each year.

8.3.8 Operator Interface Rules

- <R77> The team number settings on the Operator Interface must be set to the team number assigned to the team by *FIRST*.
- <R78> The OPERATOR CONSOLE designed by the team must fit on the 60" wide by 12" deep shelf in the Alliance Station (excluding any items that are held or worn by the DRIVERS during the match).

- <R79> Teams are permitted to connect a portable computing device (Laptop computer, PDAs, etc.) to the RS232 Output of the dashboard port of the Operator Interface for the purpose of displaying feedback from the ROBOT while participating in competition matches. Please note that ***AC power will not be available at the playing field so these devices will have to run on internal batteries.***
- <R80> The Operator Interface must be positioned within the OPERATOR CONSOLE so that the indicator lights can be clearly seen during inspection and during operation in a match. The ports on the Operator Interface must be easily and quickly accessible. This will greatly facilitate analysis by field personnel in case of problems during the competition.
- <R81> Teams cannot use Operator Interfaces from previous years' competitions.
- <R82> Nothing can be connected to the tether port of the Operator Interface during a match.
- <R83> All equipment connected to the joystick ports of the Operator Interface must be powered solely through the power available through the port. External power sources of any type are not permitted on any equipment connected to the joystick ports. Portable computing devices *can not* be connected to joystick input ports on the Operator Interface. Power-passive devices (e.g. joysticks that draw their power solely through the Operator Interface joystick port) are permitted. The one exception to this rule is Innovation First Incorporated USB adapters (IFI Part Number USB-CHICKLET) may be used to connect USB devices to the joystick ports of the Operator Interface. If used, this USB adapter must be powered with a 7.2V battery similar to the back-up battery. Teams can not use power from the competition port or any other source to power the USB adapter. The USB adapter must be positioned within the OPERATOR CONSOLE so that the indicator lights may be seen during inspection and operation in a match.
- <R84> The competition cable at the Alliance Station must connect directly to the competition port on the Operator Interface. No intermediate connectors, cables, or "pigtailed" are permitted.

8.3.9 Wiring Rules

- <R85> Electrical devices must be wired in accordance with *Section 8.3 Robot Rules*, using commercially available copper wire for all electrical connections. Aluminum (or other non-copper material) wire is prohibited. For examples of acceptable circuit designs, please see the *2007 Robot Power Distribution Diagram*.
- <R86> All wires distributing power with a constant polarity (i.e., except for relay module, speed controller, or sensor outputs) must be color-coded as follows:
- Use red, white, or brown wire for +12 Vdc and +5 Vdc connections.
 - Use black or blue wire for common (-) connections.
- <R87> *12 AWG or larger* diameter wire must be used for all circuits protected by a 40A circuit breaker.
- <R88> *14 AWG or larger* diameter wire must be used for all circuits protected by a 30A circuit breaker.

- <R89> 18 AWG or larger diameter wire must be used for all circuits protected by a 20A circuit breaker.
- <R90> 24 AWG or larger diameter wire must be used for connecting sensors such as: switches, potentiometers, accelerometers, and other sensors. 24 AWG or larger diameter wire must be used for connecting a vision system to Robot Controller inputs, and for extending the PWM cables, for the small muffin fans, or for wiring LEDs. It is acceptable to use ribbon cable smaller than 24 AWG to connect to the 9 pin ports on the Robot Controller.
- <R91> Each motor, actuator, and compressor must be connected to one, and only one, speed controller or relay module.
- <R92> CIM motors and Fisher-Price motors must be connected to speed controllers. They can not be connected to relay modules.

8.3.9.1 Circuit Breaker / Fusing Rules

<R93> The auto resetting Snap Action circuit breakers provided in the Kit Of Parts must be used to protect all active circuit breaker/ power distribution panel branch circuits from overload.

<R94> The Robot Controller power feed must be protected with a 20A circuit breaker. No other electrical load can be connected to this breaker.

<R95> The air compressor spike relay power feed must be protected with a 20A circuit breaker. No other electrical load can be connected to this breaker.

<R96> Power feeds to custom circuits and additional electronics must be protected with a 20A circuit breaker.

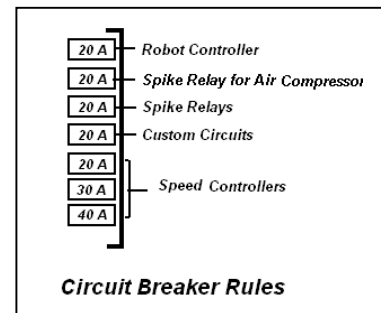

<R97> Speed controllers may be protected by 20A, 30A, or 40A circuit breakers. Speed controllers may power motors or devices of any size.

<R98> Relay modules must be protected with a 20A circuit breaker. Multiple devices may be connected to relay modules if desired (but only one motor may be connected to each relay module).

8.3.10 Pneumatic System Rules

Please refer to the *Pneumatics Manual* for additional information about using pneumatics on your ROBOT.

- <R99> Pneumatic components supplied in the Kit Of Parts (compressor, regulators, pressure switches, cylinders, valves, fittings, tubing, etc.) can not be modified except as follows:
 - The tubing may be cut.
 - The wiring for the valves and pressure switch may be modified as necessary to interface with the rest of the control system.

- Mounting and connecting pneumatics components using the pre-existing threads, mounting brackets, etc., is not considered a modification of the components. Removing the pin from the rear of an air cylinder is allowed as long as the cylinder itself is not modified.
- Do not, for example, file, machine, or abrasively remove any part of an air cylinder. Consider pneumatic components sacred. They must remain in “out of the shipping box” condition.

<R100> If pneumatics are used on the ROBOT, the pneumatic system on the ROBOT must contain as a minimum the following components, connected in accordance with this section.

- Pressure gauges to display the “working” and “stored” air pressure.
- An easily visible and accessible pressure vent valve to manually relieve the stored pressure.

<R101> The compressor may be mounted on the ROBOT, or it may be left off the ROBOT and used to pre-charge compressed air in the storage tanks prior to bringing the ROBOT onto the playing field. Off-board compressors must be controlled and powered by the ROBOT. The only difference between an on- and off-board compressor is that the off-board compressor is physically removed from the ROBOT. Note: the intent of this rule is to permit teams to take advantage of the weight savings associated with keeping the compressor off-board. But using the compressor off-board of the ROBOT does NOT permit non-compliance with any other applicable rules.

<R102> **Teams are not allowed to remove or adjust the 125-psi set relief valve attached to the compressor.** Only use the Thomas Industries compressor and up to four Clippard Instruments air storage tanks identical to those provided in the Kit can be used to compress and store air on the ROBOT. Extraneous lengths of pneumatic tubing can not be used to increase the storage capacity of the air storage system.

<R103> The Nason pressure switch must be connected to the output end of one of the Clippard tanks to sense the tank’s pressure. The two wires from the pressure switch must be connected directly to a digital input and ground terminal on the Robot Controller, and the controller must be programmed to sense the state of the switch and operate the relay module that powers the compressor. The Parker pressure vent valve must be connected to a Clippard tank such that, when manually operated, it will vent to the atmosphere to relieve any stored pressure. The valve must be placed on the ROBOT so that it is visible and accessible.

<R104> “Working” air pressure on the ROBOT must be no greater than 60psi. All working air must come from the Norgen adjustable pressure regulator, and all other pneumatic components must be downstream from this regulator. A pressure gauge must be placed adjacent to the pressure regulator and display the downstream pressure.

<R105> There is no limit to the number of solenoid valves, air cylinders, pressure regulators, and connecting fittings that may be used on the ROBOT. They must, however, be “off the shelf” pneumatic devices rated by their manufacturers for pressure of at least 125psi. Besides the “free” pneumatic components listed on the Pneumatic Components Order form, additional air cylinders or rotary actuators may be purchased. However, they must be identical to those listed on the Pneumatic Components Order form (i.e. same part numbers), and obtained from a Bimba or Parker Hannifan distributor.

<R106> The following pneumatics items may be added to the ROBOT:

- Prior year *FIRST* Kit Of Parts pneumatic cylinders, solenoid valves, and pneumatic tubing may be used in addition to those items in the 2007 Kit Of Parts. Their costs must be accounted for explained in **Section 8.3.4.3 Additional Parts - Cost Limits and Accounting**.
- A pressure transducer may be used as long as it is rated to the operating air pressure at its mounting point in the pneumatic system.
- For the purposes of the *FIRST* competition, a device that creates a vacuum is not considered to be a pneumatic device and is allowed. This includes, but is not limited to, Venturi-type vacuum generators and off-the-shelf vacuum devices (as long as they are powered by one of the Kit-of-Parts motors).
- For the purposes of the *FIRST* competition, closed-loop pneumatic (gas) shocks are not considered pneumatic devices, and are permitted additions to the ROBOT.
- Additional pressure relief valves, as needed, as long as they are identical to those supplied in the Kit Of Parts (Parker Part Number PV609-2).
- Additional 1/8 inch diameter pneumatic tubing functionally equivalent to that provided in the Kit Of Parts, with the pressure rating clearly factory-printed on the exterior of the tubing (note: alternate tubing colors are acceptable).

8.3.11 Non-Functional Decoration Rules

Teams may add “non-functional” decorations to ROBOTS under the following conditions:

- <R107> Decorations must be on the ROBOT at the time of final inspection, and must not cause the ROBOT weight or size to exceed the limits specified in Rule <R07>.
- <R108> Decorations must not affect the outcome of the match, and must be in the spirit of “Gracious Professionalism.”
- <R109> Any decorations that involve broadcasting a signal to/from the ROBOT, such as remote cameras, must be cleared with *FIRST* Engineering prior to the event and tested for communications interference at the venue. This is the one permissible exception to Rule <R66>. Note that 900 MHz camera systems will not be approved, and are not permitted at any time.
- <R110> Decorations may draw power from the 12v electrical system as long as they are powered via a dedicated 20A or 30A circuit breaker and do not affect the operation of other control system components.

8.3.12 Robot Inspection Rules

FIRST will post a copy of the Official Robot Inspection Sheet by January 19, 2007. Use this sheet as a guide to pre-inspect your ROBOT before it ships. Note that robot inspectors will be looking for sharp corners and edges that could cause injury, pinch points, entanglement hazards, and impaling projections. Please try to mitigate all such hazards.

- <R111> All ROBOTS must pass inspection for compliance with the rules herein before being allowed to compete in qualification matches. At the time of inspection, teams must present a list of all Non-Kit Of Part items and costs used in the construction of their ROBOT to the inspector.

- <R112> At inspection, noncompliance with any robot construction rule may result in disqualification of the ROBOT from the *FIRST* competition event. The team must bring the ROBOT into compliance before they will be allowed to compete in qualification matches. At the discretion of the lead Inspector, the ROBOT may be allowed to participate in practice matches before passing inspection.
- <R113> If a team makes a modification to improve performance or reliability after their ROBOT has passed inspection, that team must have the ROBOT re-inspected. If an observation is made that another team's ROBOT may be in violation of the robot rules, please approach *FIRST* officials to review the matter in question. This is an area where "Gracious Professionalism" is very important.
- <R114> At the time of inspection, the ROBOT must be presented with **all** mechanisms (including **all** components of each mechanism) **and configurations** that will be used on the ROBOT during the entire competition event. It is acceptable, however, for a ROBOT to play matches with a **subset** of the mechanisms that were present during inspection. Only mechanisms that were present during the inspection may be added, removed or reconfigured between matches. If subsets of mechanisms are changed between matches, the reconfigured ROBOT must still meet all inspection criteria.
- <R115> If a ROBOT is rejected because of a safety issue or concern related to the team's method of storing energy (see Rule <R02>), the concerned mechanisms must be disabled or removed from the ROBOT before it can compete in a match. The team bears the burden of proof that such a rejection is not valid. Teams should be prepared to provide justifiable test data or calculations during inspection to support their design.
- <R116> *FIRST* Officials may randomly re-inspect ROBOTS participating in competition matches to assure compliance with the rules.