

CONNECTOR TUBE

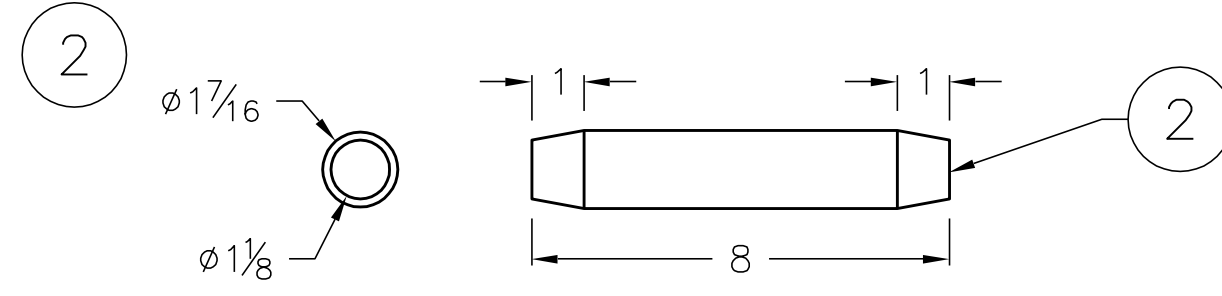

CONNECTOR SHAFT

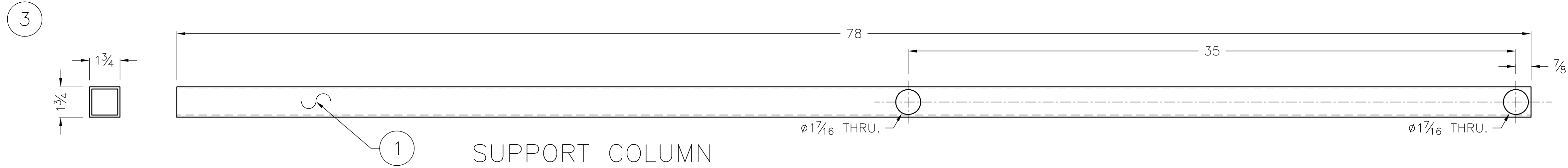

SUPPORT COLUMN

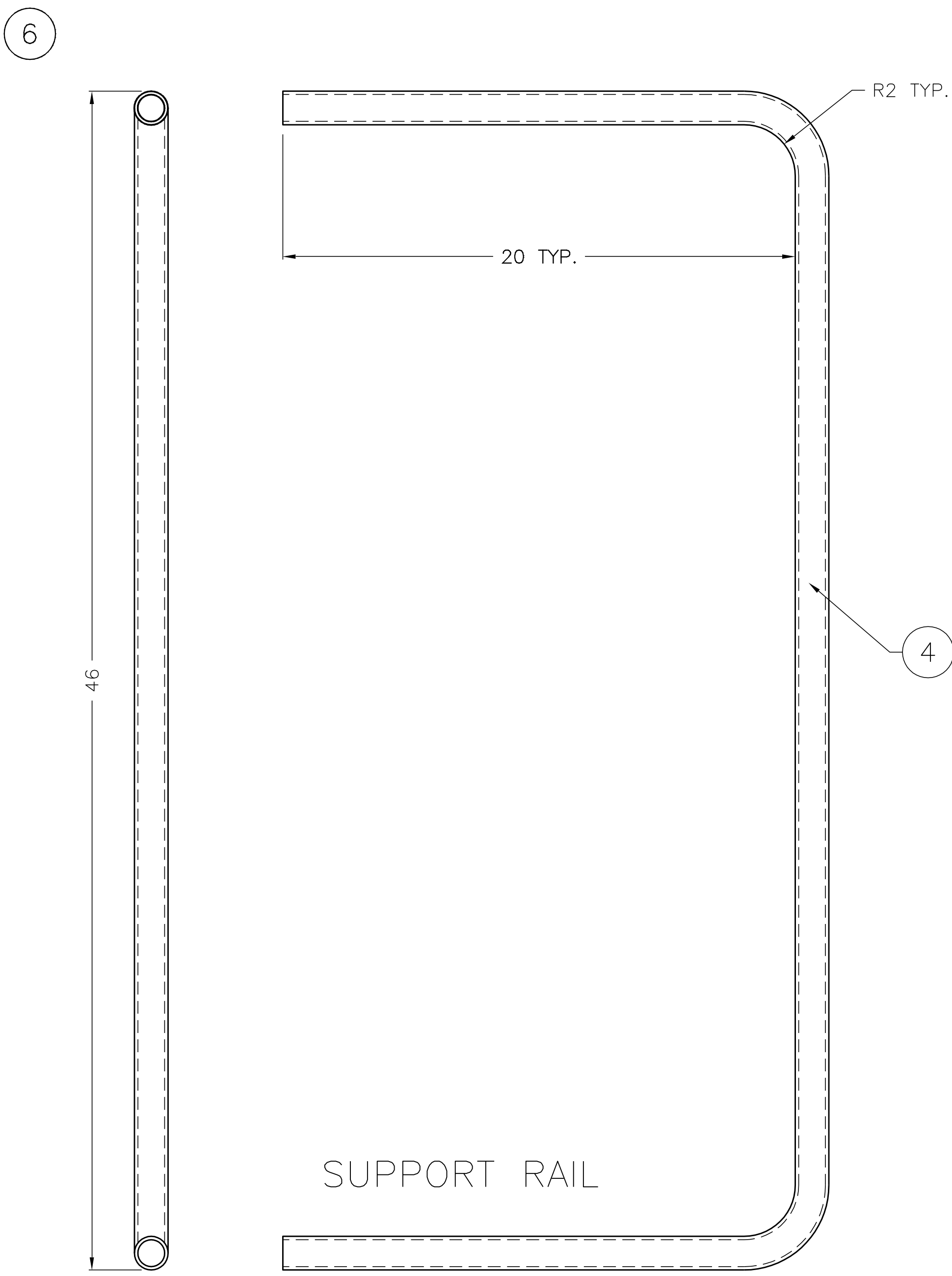

SUPPORT RAIL

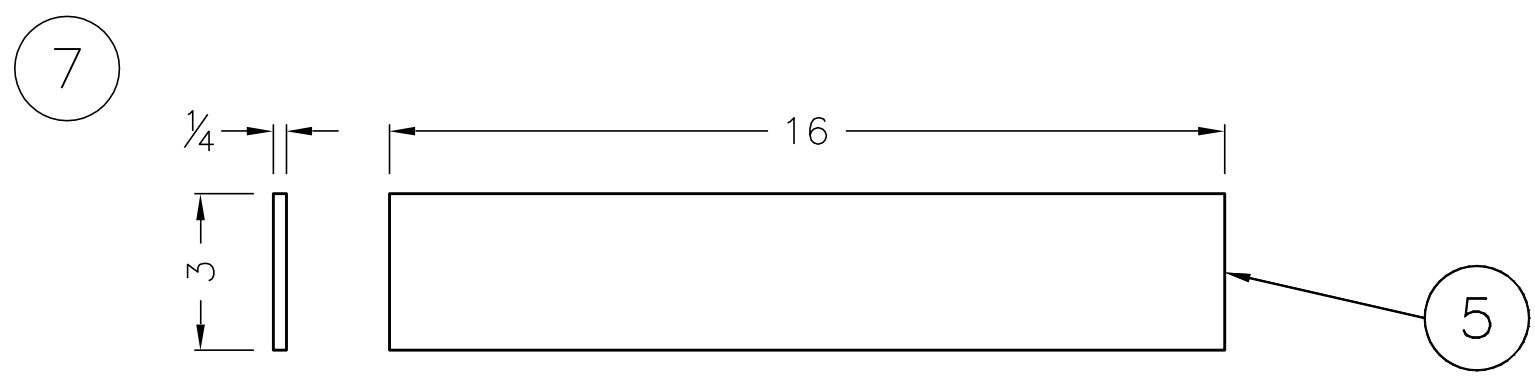

STOP PLATE

ZONE		REV		REVISIONS		DATE	APPROVED

ITEM	QTY.	DESCRIPTION	LENGTH	PART NO.
1	2	CONNECTOR TUBE	.	-
2	2	CONNECTOR SHAFT	.	-
2	1	SUPPORT COLUMN	.	-
.	.	.	.	-

ITEM	QTY.	DESCRIPTION	LENGTH	PART NO.
1	1	1 3/4"x1 3/4"x1/8" 6061 ALUMINUM TUBING	.	-
2	1	1 1/2" 6061 ALUMINUM SOLID ROD	.	-
.	.	.	.	-

NOTE:
REMOVE ALL SHARP EDGES.

FIRST 200 Bedford Street, Manchester, N.H. 03101 (603) 666-3906 ♦ FAX (603) 666-3907		DRIVERS STA. SUPPORT FABRICATION		MATERIAL AS NOTED	
1 PER MARK-UPS REV. FROM BY DATE	JR 1/5 BY DATE	DRAWN BY JRR	DATE 09/27/04	SCALE 1:4	CHECKED DATE
UNLESS OTHERWISE SPECIFIED TOLERANCE PERPENDICULAR WITHIN INCHES PARALLEL FRAC. 1/32 FLAT OR STRAIGHT CONCENTRIC T.I.R.		RADIi : 1/4 HOLES : 1/2 FSCM	SURFACE FINISH	SIZE D	SHEET NO. 1
No. F05-0003			1		