

Section

10



GET PUBLISHED

Table of Contents

Content of the Book

How it all Works

Submission Requirements

Electronic Submission Requirements

Submission Questionnaire

FAQs

Grant of Rights



ROBOTS

Behind the Design



Get Published!

Rockport Publishers will be publishing a book featuring 30 award-winning robots from the 2006 FRC competition that demonstrate engineering and design excellence. Each of the robots featured will be documented over several pages outlining the design and the design processes used through information and process images that the FRC teams supply. This book, the only one of its kind, will offer technology enthusiasts, including FRC members interested in learning how creative processes are applied to develop sophisticated robots, with an intimate understanding of what it took to design and build these winning robots. The book will be published and available through major bookstore chains such as Amazon, Borders, and B&N, as well as around the globe and possibly in multiple languages, in the fall of 2007.

About the Publisher



Rockport Publishers specializes in books for design professionals—their publishing program includes product design, graphic design, interior design, and architecture. Their worldwide book distribution offers designers the opportunity to show their work in an international forum. Please visit their website at www.rockpub.com.

The Content of the Book

The book will feature approximately 30 robot designs that demonstrate exceptional performance in the following award categories at the regional events and championships. Only winners of at least one of these awards at the regional or championship level will be eligible for consideration.

- Delphi Driving Tomorrow's Technology Award
- General Motors Industrial Design Award
- Motorola Quality Award
- RadioShack Innovation in Control Award
- Xerox Creativity Award

How It all Works

The book will be written based on information provided by teams participating in the 2006 competition. Only FRC 2006 teams who have won one of the above mentioned awards are invited to submit documentation of their design efforts for consideration as a featured profile/case-study that will be included in the book. The submitted information will form the raw material the book is created from so please provide visuals of all kinds and from all points during the development process. This is extremely important because if you do not submit enough written information or visuals, you will not be eligible for consideration.

Teams that want to be considered for inclusion in this book must document their design process and submit that documentation to FIRST no later than exactly one month from the day the award was won. FIRST will forward your submission to the book judges. The judges will select designs to be included in the book from those submitted by teams winning one of the above awards. Winning an award is not a guarantee to be published, BUT the quality of your submitted material will be a very important factor in determining which robots will be chosen for inclusion.

Submission Requirements

If you are submitting for more than one award, please provide a separate and complete package for each, clearly labeled with the team number and the award you are submitting for. You must provide the following materials in order to be eligible for consideration:

- A fully filled out questionnaire submitted as a Microsoft Word document
- A minimum of 15 images submitted according to the *Electronic Submission Guidelines* attached
- A signed Grant of Rights form

A series of questions have been prepared for each award and teams must answer these questions thoroughly and completely. They must also provide an in-depth narrative of the design and development process as one part of their submitted material. Teams must also include a minimum of 15 high-quality graphic images (see *Electronic Submission Guidelines*) that illustrate the evolution of their robot design from inception to its final creation. These graphic images must include a final image (or two) of the finished robot shot clearly against a white background or wall, as well as the following:

- Original hand-sketches of robot
- Photographs of robot concepts, development, or prototypes
- CAD models of robot
- Detail photographs of the robot's important features
- Photographs of the robot during the building process

The submitted graphics are as important as the submitted text to tell the story of how your team progressed from idea to reality so a good variety of types of images from sketches to completion will communicate this best. Be sure to read the *Electronic Submissions Guidelines* very carefully so you are sure you are supplying the correct content.

Electronic Submission Guidelines:

Files may be provided on either a MAC or PC formatted media: (be sure to copy MAC files to MAC formatted disks...MAC files copied onto PC formatted disks may be corrupted). Files must be sent on one of the following media: ZIP (100MB), CD-ROM, or DVD.

Submit 2 copies of your files (keep the original) with the following specifications:

Size and format:

- 350 dpi resolution or (72 DPI for screen grabs only)
- **Minimum** size 4" x 5" (larger dimensions preferred)
- **.TIFF** or **.EPS** files only- RGB color or CYMK color
- Illustrator files need to be EPS and all fonts need to be converted to outline (vector)

Do NOT send JPG, Quark Express files, Quick Time, PDF, PSD, GIF, or Pagemaker files, they will not be accepted. The only accepted files are TIFF or EPS

The information you provide will be used in a credit to accompany your submission and in the directory should it be selected, so write legibly, be as complete as possible, and double check all spelling. Incomplete or illegible forms will be disqualified.

Note to teams: You can convert Autodesk Inventor files to .TIFF files by saving them as .bmp files, opening them in Paint, and resaving as .TIFF.

Labeling Submission:

Please label each disk with the following information:

- FIRST Robot Book
- Team Number
- Award submission is for
- Contact Name
- Contact Phone Number

Include the following items with the disk:

- Disk directory printout listing contents of the disk
- 8" x 10" color or black and white print out (hi resolution on photo paper) of each image labeled with
 1. Team number
 2. File name(s)
 3. Award submission is for
 4. File Format (.TIFF, .EPS)
 5. File size in megabytes (Mb)
 6. Image size (inches or metric)
 7. DPI (resolution)
- Completed "Grant of Rights" form (included in following pages)
- Completed "Submission Questionnaire" (included in following pages) in a Word .doc format

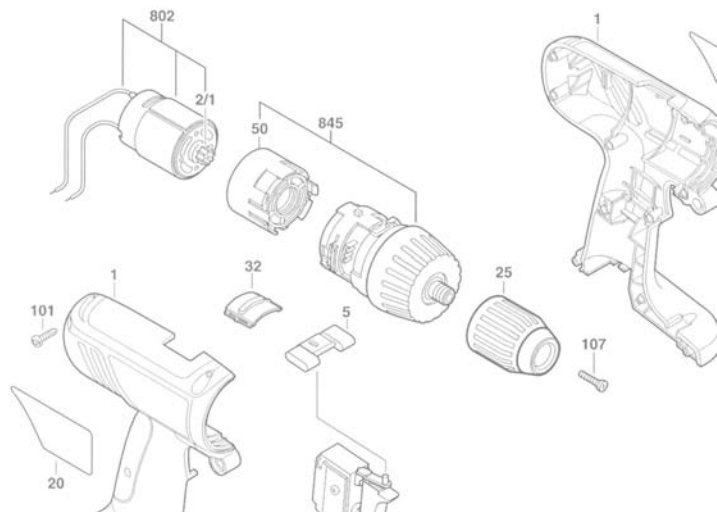

Packaging/Shipping

Package all media well for shipping. We recommend a padded envelope and do not use paper clips, binder clips, or staples near any photographs as they will damage the images.

Send the complete submission package to:

FIRST Robotics Competition
FIRST Robot Book Opportunity
200 Bedford Street
Manchester, NH 03102

You must include your team number on the package as part of the return address.

Deadline to submit materials: Must be postmarked **no later than exactly one month from the day the award was won.**

Take the time to double check that you have put everything in the package, that all the forms are completed, all criteria is met and the disk can be read before you mail it to FIRST. **Incomplete packages will not be forwarded to the author.**

Upon publication, teams whose work is selected for the book will be notified and will receive a 50% discount on purchasing unlimited copies of the book.

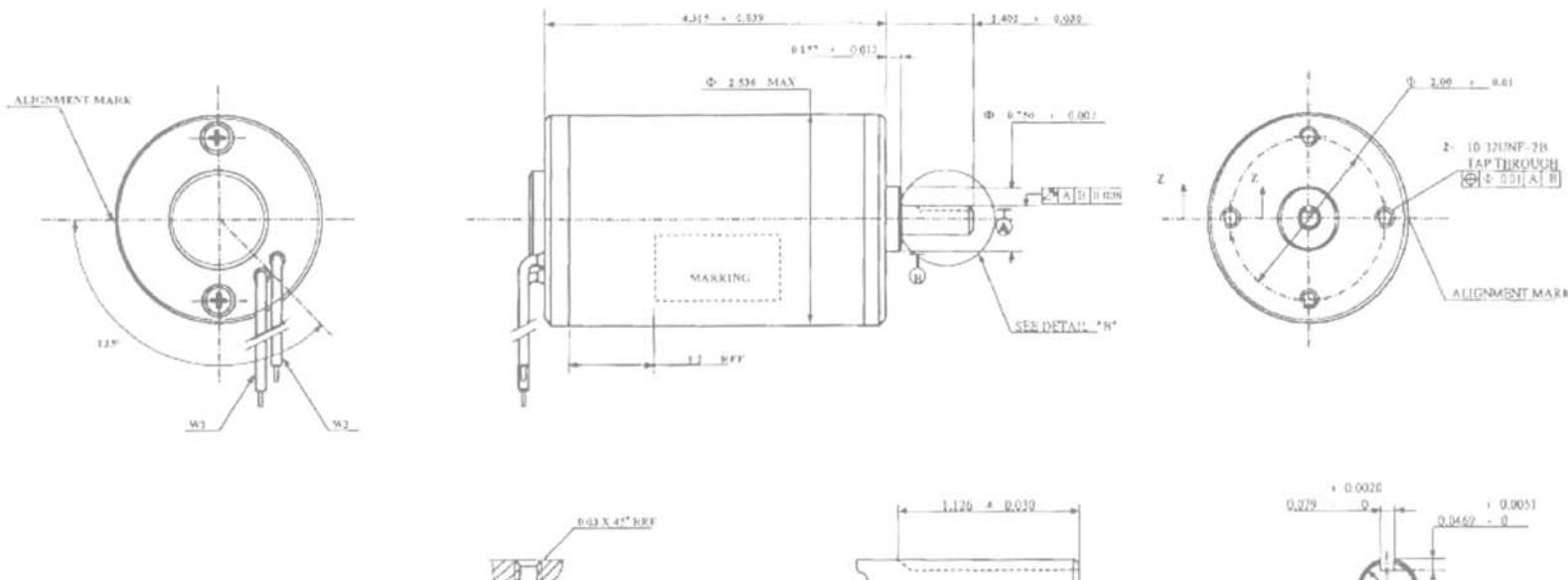

Submission Questionnaire

The following team questions will aid in the creation of the *FIRST Book of Robot Design*. Questions must be submitted as a Word document.

The “General Robot Description Question” must be completed for every award submission.

General Robot Description Question:

Please describe in-depth the design, development process, and any challenges you faced along the way. Provide step-by-step images to illustrate the important moments.

Award: General Motors Industrial Design – This award celebrates form and function in an efficiently designed machine that effectively achieves the established challenge.

Questions:

1. Describe your team’s strategy for playing the 2006 FRC game.
2. What was the most important feature or function to execute your game strategy? Describe its function and the problems solved while creating and constructing this feature.
3. Please provide specific examples of overcoming the design challenges created by limits of time and resources.
4. What assembly and integration problems were solved while building the robot?
5. What was the most difficult portion of the design process (idea generation, selection of alternatives, analysis, fabrication, testing, integration) and why? Please walk us through the design that produced your machine.
6. What features had to be sacrificed in order to achieve the present machine?
7. Did practices reveal any unexpected features of the machine (positive or negative)?
8. Is this machine modeled on any real world systems, or can the design be applied to any real world system? If so, please explain the relationship between the machine and other existing systems.

Award: Delphi “Driving Tomorrow’s

Technology”– This award celebrates an elegant and advantageous machine feature, which includes any aspect of engineering elegance including, but not limited to: design, wiring methods, material selection, programming techniques, and unique machine attributes. The criteria for this award is based on the team’s ability to verbally describe in a concise manner, as well as demonstrate, this chosen machine feature.

Questions:

1. What was the machine feature that won this award?
2. How does the feature contribute to the robot’s performance?
3. Describe the design process of that feature, from initial ideas to concepts to prototypes to final design.
4. What design alternatives were suggested for this machine feature before the chosen design was selected?
5. What engineering analysis was done before the device was constructed?
6. Was any software used as a design tool? Please describe how that software benefited the design process.
7. What challenges were overcome in getting the feature functioning on the robot?
8. When was the first functioning prototype of this feature ready for testing, and how was that testing accomplished?
9. Was the feature modified during testing to improve performance?
10. How did team members guide the design and development of this feature?

Award: Motorola Quality – This award celebrates machine robustness in concept and fabrication.

Questions:

1. What makes this machine robust?
2. Provide some examples of how the machine's robustness contributes to the machine's performance.
3. What factors established the need for a robust design?
4. What was the most important component in the Kit of Parts in the area of machine robustness?
5. How did experimentation and testing assist in creating a high quality robot?
6. What research was conducted to aid the design process?
7. What were the goals and objectives of this design and how did these goals result in producing the high quality finished product?
8. Describe the creative process (from brainstorming to the final build).
9. Where did your design inspiration come from?
10. Before products are developed, a series of design reviews are often conducted, such as Concept Review and Selection, Preliminary Design Review, Design Safety Review, Prototype Review, Customer Testing Review, Detailed Design Review, Quality Review). Though your team may not have established a formal review process, can you describe how the design was reviewed and improved over the six week time period?

Award: Xerox Creativity – This award celebrates creative design, use of a component, or a creative or unique strategy of play.

Questions:

1. What are the creative attributes of your design?
2. Creativity can either be instantaneous (i.e. the Eureka moment) or the result of a systematic process to generate ideas (such as brainstorming, using analogies, applying checklists, word associations, manipulating an existing solution). Please describe the process which produced the creative aspect of your design.
3. What design ideas or robot functions were thought of but not implemented on the final robot, and why?
4. For the existing design, how many different alternatives were considered and why was the existing system selected?
5. Moving from an idea to reality is often difficult. How has the design changed from its original concept to the constructed device?
6. How did the FIRST robot rules or FIRST game rules affect your creative process?
7. What design tools were used to first describe the idea, refine the design, and construct the device? (Note these tools may range from a sketch, to a CAD model, to engineering calculations).
8. Did the schedule impact your creative process? Did the time constraint force an alternative solution? Did the small amount of time for the entire process (from inception, to concept, to prototype, to testing, to refinement, to final design) dampen creativity?

Award: Radio Shack Leadership in Control –

This award celebrates an innovative control system or application of control components to provide unique machine functions.

Questions:

1. What is the innovative control or application of control components on your robot?
2. What can the robot do in autonomous mode, and how does it accomplish those tasks?
3. Control requires an integration of the hardware and software on a robot. Can you describe how the software was integrated with the robot mechanisms and sensors?
4. How did the design of the control system morph while the robot was developed and what aspects of the robot design influence the control system the most?"
5. How did the control system improve human-machine interaction? (For example, many teams program in dead bands for motors, change the slope of the input to output relationships for joysticks and motors, or use other means to improve the human's ability to control the robot).
6. What sensors were used in the control system and how were these sensors used?
7. Was the control system "bench tested" before being implemented on the robot, and what was discovered from those original tests? How was the control system tested?
8. Control is based on feedback. What forms of feedback to the human and the robot are achieved in your design and how is the feedback measured?
9. How does the control function contribute to the robot's performance?
10. Was the machine designed with control in mind, or was the control system built to accommodate the mechanical design?
11. What surprises were discovered during the development of the control system?

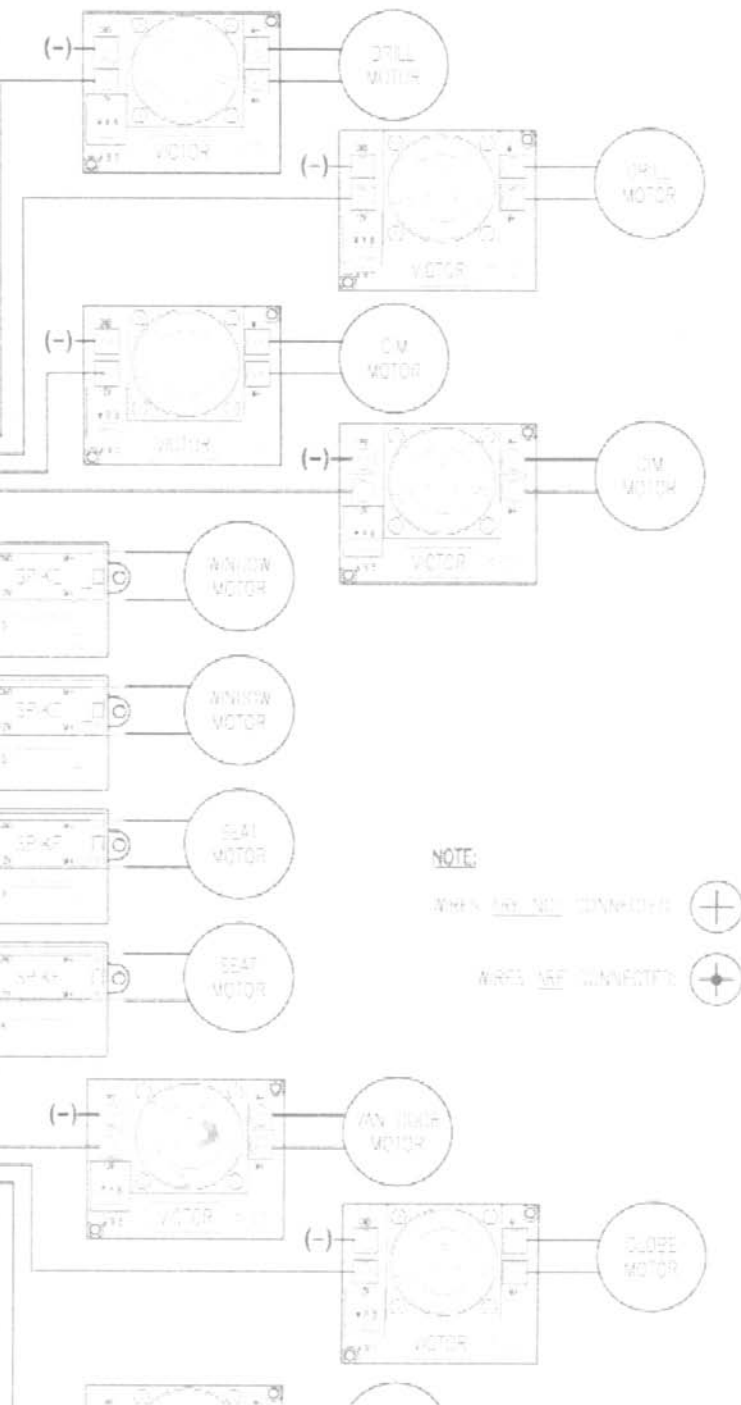

F.A.Q.'s

Q. Who owns the design?

A. The team will continue to own the design. By signing the "Grant of Rights" form, the team is giving permission for Rockport Publishers to publish the design (read the Grant of Rights form for specific rights being granted).

Q. Will someone be able to patent our design from the book?

A. The book will contain a copyright statement indicating that all of the photos and drawings are property of the team who submitted them.

Q. Will teams get any payment for being published?

A. No.

Q. What happens if the disk is corrupted, can we resubmit?

A. We encourage all teams to double check the package before they submit. Due to the planned timing of getting this book written and published, any problems with the submission package will decrease the odds that a team will be considered as a robot design case study for this book.

Q. Will someone contact our team to ask us questions about our design?

A. The "Submission Questionnaire" is designed to give the author all the information needed to publish the book. Be sure to complete it fully. Teams may wish to emphasize one award over others in their submitted material.

Q. When will we know if our team has been selected to be published?

A. Teams will know if their submission was chosen upon publication, currently scheduled for September 2007.

Q. We created all of our CAD drawings using Autodesk Inventor. How do we convert these files to .EPS or .TIFF files?

A. You can convert Autodesk Inventor files to .TIFF files by saving them as .bmp files, opening them in Paint, and resaving as .TIFF. You cannot convert them to .EPS.

Q. How do I submit a Word.doc when the submission questionnaire is in a .pdf format?

A. Acrobat Reader has a Select Text tool. Use it to highlight the Submission Questionnaire portion of the .pdf file and copy to Clipboard (PC users, right mouse click). Open a new Word document and paste the copied text. This will allow you to answer the questions using Word and without retyping.

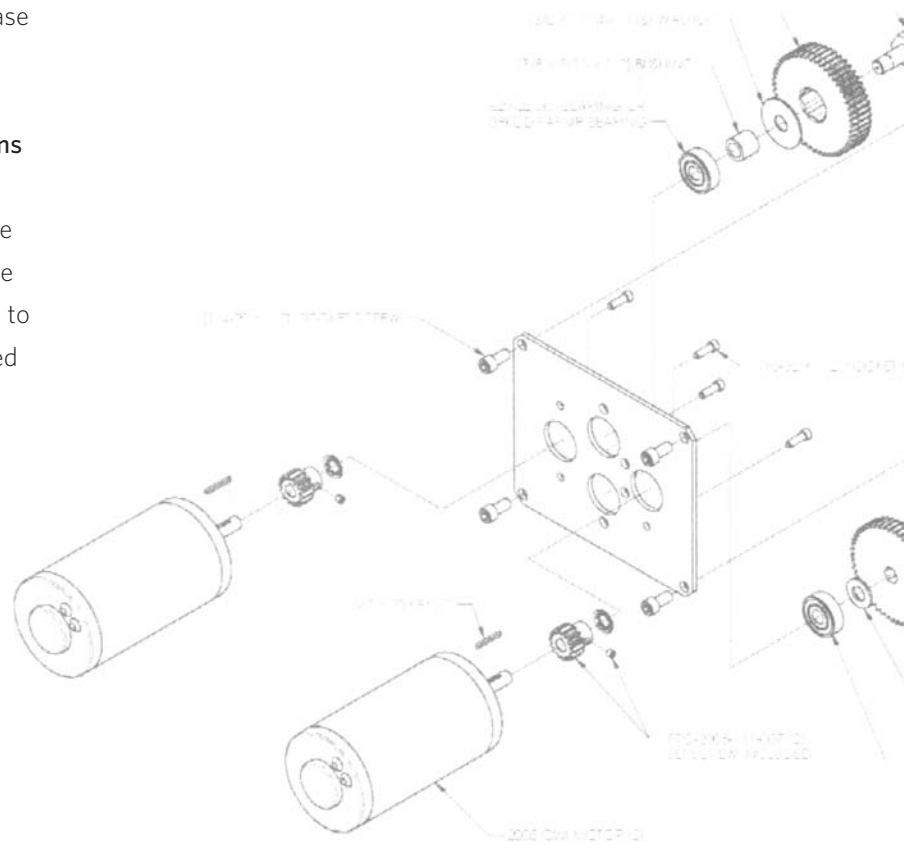

Grant of Rights:

The undersigned hereby grants to Rockport Publishers the right to reproduce in any size the work identified below in its forthcoming book tentatively titled **First Robots: Behind the Design** in all editions, revisions and the reprintings of the Book, and promotional and instructional materials thereto; in all known or hereafter invented media which makes the Book available in visual form for reading, and as a contribution to other collective works in all such media. The undersigned hereby confirms that (1) any and all information attached hereto is correct, (2) the undersigned is either the sole owner of all rights to the work (and to any and all photographs, samples, and transparencies of the work being submitted) or has been authorized by the owner(s) of such rights to grant the rights herein granted and (3) the publication of the work will not violate the rights of any third party. The undersigned agrees that (1) the undersigned will not receive any direct financial compensation from Rockport for granting these rights herein, but has and will receive as good and valuable consideration for granting these rights the promotional value of having the work included in the Book, (2) materials submitted will not be returned, (3) the undersigned shall not hold Rockport Publishers responsible for the safekeeping of any materials in Rockport's possession, and (4) Rockport Publishers is under no obligation to include the above-mentioned work in the Book or to publish the Book itself. We also agree that Rockport Publishers is entitled to rely for permission on a facsimile of this original.

Contributors will not receive complimentary copies as a result of their work being included in the book unless this is pre-approved by the publisher in writing.

Please fill out and submit a separate Grant of Right for each award you are submitting for.

Fill this out so it reads exactly how you would like your information listed in the directory of the book. If you DO NOT want your address listed, please let us know.

AWARD:

TEAM NAME AND NUMBER:

ADDRESS:

PHONE NUMBER:

FAX NUMBER:

E-MAIL:

LIST ALL MENTORS AND MEMBERS OF TEAM:

(PRINT) NAME:

SIGNATURE

DATE